



Multipath Management API

Version 1.1

“This document has been released and approved by the SNIA. The SNIA believes that the ideas, methodologies and technologies described in this document accurately represent the SNIA goals and are appropriate for widespread distribution. Suggestion for revision should be directed to <http://www.snia.org/feedback/>”

SNIA Technical Position

March 8, 2010

Revision History

| Revision | Date | Sections | Originator: | Comments |
|----------|--------------------|---|-------------|---|
| 1 | 1 October 2008 | All | Hyon Kim | First draft of version 1.1 |
| 2 | 25 March 2009 | 6.8, 6.25, 6.28, 7.28 | Hyon Kim | Captured Device Product category and Path statistics discussion. |
| 3 | 6 April, 2009 | 6.28 – 6.32 7.29 | Hyon Kim | Moved statistics bucket related structures to separate sections. New interface for distributed statistics is added. |
| 4 | 20 May, 2009 | 7.43 | Hyon Kim | Modified buffer names for SendSCSI interface to dataIn/dataOut. |
| 5 | 25 September, 2009 | 5.6, 6.15, 6.29, 6.34 D.5 | Hyon Kim | Statistics illustration, SAS transport type description, statistics type for read/write operations, snaptime description, and code example for distributed statistics are added. MP_STATISTICS_RANGE_MODE and timeSinceLastReset are removed. |
| 6 | 10 October, 2009 | 5.6, 6.8, 6.15, 6.18, 6.25, 6.28, 6.29, 6.30, 6.31, 6.32, 7.2, 7.25, 7.28, 7.36, 7.42, 7.43, 7.44, D.5, D.6 | Hyon Kim | Incorporated comments from TWG meeting on 10/1. Added code example D.5 and moved illustration of distributed statistics example from the code example to section 5.6 Statistics. Added MP_STATUS_LU_NONOPERATIONAL status to interface MP_GetMPLogicalUnitProperties. |
| 7 | 15 October, 2009 | 5.6, 6.8, 6.15, 6.18, 6.25, 6.28, 6.29, 6.30, 6.31, 6.32, 6.33, 6.36, 7.2, 7.25, 7.28, 7.29, 7.36, 7.42, 7.43, 7.44, D.5, D.6 | Hyon Kim | Incorporated comments from TWG meeting on 10/15. Fixed various typos. Section 6.28 MP_STATISTICS_UNSUPPORTED is newly added. Description of relativeID in section 6.36 is fixed. Added statements in Remarks section for checking support for |

| | | | | |
|----|-------------------|---|----------|---|
| | | | | <p>section 7.29 MP_GetPathLogicalUnitDistributedS tatistics interface.</p> |
| 8 | 5 November, 2009 | 5.6, 6.25, 6.33, D.5, D.6 | Hyon Kim | <p>Changed *bytesRead to *readBytes and *bytesWrite to writeBytes. The range value of MP_STATISTICS_BUCKET is defined as non-inclusive upper limit.</p> <p>MP_DEVICE_PRODUCT_* shifts starts with 0 instead of 1.</p> <p>MP_STATITSTICS_DATA_TYPE_* changed to bit flag and proprietary data type is defined.</p> |
| 9 | 30 November, 2009 | 6.30, 6.32, 6.33, 6.34 | Hyon Kim | <p>Added more data types for distributed statistics data.</p> <p>Added MP_DISTRIBUTED_STATISTICS_ MODE.</p> <p>Updated timeUnit definition. Changed range to boundary for MP_STATISTICS_BUCKET.</p> |
| 10 | 4 December, 2009 | <p>All sections that are modified or added for Version 1.1</p> <p>5.6, 6.8, 6.15, 6.25, 6.28, 6.29, 6.30, 6.31, 6.32, 6.33, 6.34, 6.36, 7.2, 7.28, 7.29, 7.36, 7.42, 7.43, 7.44, D.5, D.6</p> | Hyon Kim | <p>Fixed more editorial errors through TWG review.</p> <p>Completed updates for SNIA TC review.</p> |

Suggestion for changes or modifications to this document should be sent to
<http://www.snia.org/feedback/>.

The SNIA hereby grants permission for individuals to use this document for personal use only, and for corporations and other business entities to use this document for internal use only (including internal copying, distribution, and display) provided that:

- 1.Any text, diagram, chart, table or definition reproduced must be reproduced in its entirety with no alteration, and,
- 2.Any document, printed or electronic, in which material from this document (or any portion hereof) is reproduced must acknowledge the SNIA copyright on that material, and must credit the SNIA for granting permission for its reuse.

Other than as explicitly provided above, you may not make any commercial use of this document, sell any or this entire document, or distribute this document to third parties. All rights not explicitly granted are expressly reserved to SNIA.

Permission to use this document for purposes other than those enumerated above may be requested by e-mailing tcmd@snia.org please include the identity of the requesting individual and/or company and a brief description of the purpose, nature, and scope of the requested use.

Copyright © 2010 Storage Networking Industry Association.

CONTENTS

| | |
|--|-----------|
| 1 SCOPE | 1 |
| 2 NORMATIVE REFERENCES..... | 1 |
| 3 TERMS, DEFINITIONS AND ABBREVIATIONS..... | 2 |
| 3.1 TERMS AND DEFINITIONS | 2 |
| 3.2 ABBREVIATIONS..... | 4 |
| 4 DOCUMENT CONVENTIONS | 4 |
| 5 BACKGROUND TECHNICAL INFORMATION | 5 |
| 5.1 OVERVIEW..... | 5 |
| 5.2 TARGET PORT GROUPS | 6 |
| 5.3 RELATIONSHIP BETWEEN TARGET PORT GROUPS IN SCSI AND IN THIS API..... | 6 |
| 5.3.1 <i>General</i> | 6 |
| 5.3.2 <i>Symmetric and asymmetric multipath access</i> | 9 |
| 5.3.3 <i>Logical unit affinity groups</i> | 10 |
| 5.3.4 <i>Load balancing</i> | 10 |
| 5.3.4.1 <i>General</i> | 10 |
| 5.3.4.2 <i>Load balancing algorithms</i> | 10 |
| 5.3.4.3 <i>Administrative preference – path weight</i> | 11 |
| 5.3.4.4 <i>Disable load balancing – override path</i> | 11 |
| 5.3.4.5 <i>Disable path</i> | 11 |
| 5.3.5 <i>Model overview</i> | 12 |
| 5.4 CLIENT DISCOVERY OF OPTIONAL BEHAVIOR | 13 |
| 5.4.1 <i>General</i> | 13 |
| 5.4.2 <i>Discovery of load balancing behavior</i> | 14 |
| 5.4.3 <i>Client discovery of failover/failback capabilities</i> | 15 |
| 5.4.4 <i>Client discovery of a driver’s OS device file name behavior</i> | 15 |
| 5.4.5 <i>Client discovery of auto-failback capabilities</i> | 15 |
| 5.4.6 <i>Client discovery of auto-probing capabilities</i> | 16 |
| 5.4.7 <i>Client discovery of support for LU assignment to target port groups</i> | 17 |
| 5.5 EVENTS..... | 17 |
| 5.6 STATISTICS | 17 |
| 5.7 API CONCEPTS..... | 20 |
| 5.7.1 <i>Library and plugins</i> | 20 |
| 5.7.2 <i>OS-independent implementation</i> | 20 |
| 5.7.3 <i>Object ID</i> | 21 |
| 5.7.4 <i>Object ID list</i> | 22 |
| 6 CONSTANTS AND STRUCTURES..... | 22 |
| 6.1 MP_WCHAR..... | 22 |
| 6.2 MP_CHAR..... | 22 |
| 6.3 MP_BYTE | 22 |
| 6.4 MP_BOOL..... | 22 |
| 6.5 MP_XBOOL | 22 |
| 6.6 MP_UINT32..... | 22 |
| 6.7 MP_UINT64..... | 22 |
| 6.8 MP_STATUS | 22 |
| <i>Status values</i> | 22 |

| | |
|---|----|
| MP_STATUS_LU_NONOPERATIONAL..... | 23 |
| 6.9 MP_PATH_STATE | 23 |
| <i>Constants</i> | 24 |
| <i>Definitions</i> | 24 |
| <i>Remarks</i> | 24 |
| 6.10 MP_OBJECT_VISIBILITY_FN | 24 |
| <i>Format</i> | 24 |
| <i>Parameters</i> | 24 |
| <i>Remarks</i> | 25 |
| 6.11 MP_OBJECT_PROPERTY_FN | 25 |
| <i>Format</i> | 25 |
| <i>Parameters</i> | 25 |
| <i>Remarks</i> | 25 |
| 6.12 MP_OBJECT_TYPE | 25 |
| <i>Constants</i> | 25 |
| <i>Definitions</i> | 26 |
| 6.13 MP_OID..... | 26 |
| <i>Format</i> | 26 |
| <i>Fields</i> | 26 |
| <i>Remarks</i> | 26 |
| 6.14 MP_OID_LIST..... | 27 |
| <i>Format</i> | 27 |
| <i>Fields</i> | 27 |
| <i>Remarks</i> | 27 |
| 6.15 MP_PORT_TRANSPORT_TYPE..... | 27 |
| <i>Constants</i> | 27 |
| <i>Definitions</i> | 27 |
| <i>Remarks</i> | 28 |
| 6.16 MP_ACCESS_STATE_TYPE..... | 28 |
| <i>Constants</i> | 28 |
| <i>Definitions</i> | 28 |
| <i>Remarks</i> | 28 |
| 6.17 MP_LOAD_BALANCE_TYPE..... | 29 |
| <i>Constants</i> | 29 |
| <i>Definitions</i> | 29 |
| <i>Remarks</i> | 29 |
| 6.18 MP_PROPRIETARY_PROPERTY | 30 |
| <i>Format</i> | 30 |
| <i>Fields</i> | 30 |
| <i>Remarks</i> | 30 |
| 6.19 MP_PROPRIETARY_LOAD_BALANCE_PROPERTIES | 30 |
| <i>Format</i> | 30 |
| <i>Fields</i> | 30 |
| <i>Remarks</i> | 30 |
| 6.20 MP_LOGICAL_UNIT_NAME_TYPE..... | 30 |
| <i>Constants</i> | 30 |
| <i>Definitions</i> | 31 |
| <i>Remarks</i> | 31 |
| 6.21 MP_LIBRARY_PROPERTIES | 31 |

| | |
|--|----|
| <i>Format</i> | 31 |
| <i>Fields</i> | 31 |
| 6.22 MP_AUTOFAILBACK_SUPPORT | 32 |
| <i>Constants</i> | 32 |
| <i>Definitions</i> | 32 |
| <i>Remarks</i> | 32 |
| 6.23 MP_AUTOPROBING_SUPPORT..... | 32 |
| <i>Constants</i> | 32 |
| <i>Definitions</i> | 32 |
| <i>Remarks</i> | 33 |
| 6.24 MP_PLUGIN_PROPERTIES | 33 |
| <i>Format</i> | 33 |
| <i>Fields</i> | 33 |
| 6.25 MP_SUPPORTED_DEVICE_PRODUCT_CATEGORY..... | 35 |
| <i>Constants</i> | 35 |
| <i>Definitions</i> | 35 |
| <i>Remarks</i> | 36 |
| <i>See Also</i> | 36 |
| 6.26 MP_DEVICE_PRODUCT_PROPERTIES | 36 |
| <i>Format</i> | 36 |
| <i>Fields</i> | 36 |
| <i>Remarks</i> | 37 |
| 6.27 MP_MULTIPATH_LOGICAL_UNIT_PROPERTIES..... | 37 |
| <i>Format</i> | 37 |
| <i>Fields</i> | 37 |
| <i>Remarks</i> | 39 |
| 6.28 MP_STATISTICS_UNSUPPORTED | 39 |
| 6.29 MP_TIME_RESOLUTION_UNIT..... | 39 |
| <i>Constants</i> | 39 |
| 6.30 MP_STATISTICS_DATA_TYPE..... | 40 |
| REMARKS | 41 |
| THE STATISTICS DATA TYPE IS USED WITHIN THE CONTEXT OF MP_PATH_LOGICAL_UNIT_DISTRIBUTED_STATISTICS. | 41 |
| 6.31 MP_STATISTICS_BUCKET | 41 |
| FORMAT | 41 |
| REMARKS | 41 |
| THE VALUE OF THE BOUNDARY FIELD REPRESENTS EITHER TIME OR A COUNTER DEPENDING ON THE TYPE OF STATISTICS DATA THAT THE BUCKET CONTAINS. | 41 |
| 6.32 MP_DISTRIBUTED_STATISTICS_MODE | 41 |
| REMARKS | 42 |
| 6.33 MP_PATH_LOGICAL_UNIT_DISTRIBUTED_STATISTICS | 42 |
| 6.34 MP_PATH_LOGICAL_UNIT_STATISTICS..... | 42 |
| <i>Format</i> | 42 |
| <i>Fields</i> | 43 |
| 6.35 MP_PATH_LOGICAL_UNIT_PROPERTIES..... | 44 |
| <i>Format</i> | 44 |
| <i>Fields</i> | 45 |
| <i>Remarks</i> | 45 |
| 6.36 MP_INITIATOR_PORT_PROPERTIES | 45 |

| | |
|---|-----------|
| <i>Format</i> | 45 |
| <i>Fields</i> | 45 |
| <i>Remarks</i> | 46 |
| 6.37 MP_TARGET_PORT_PROPERTIES | 46 |
| <i>Format</i> | 46 |
| <i>Fields</i> | 46 |
| <i>Remarks</i> | 47 |
| 6.38 MP_TARGET_PORT_GROUP_PROPERTIES | 47 |
| <i>Format</i> | 47 |
| <i>Fields</i> | 47 |
| 6.39 MP_TPG_STATE_PAIR | 47 |
| <i>Format</i> | 47 |
| <i>Fields</i> | 47 |
| <i>Remarks</i> | 48 |
| 7 APIS..... | 48 |
| 7.1 API OVERVIEW | 48 |
| 7.2 MP_ADDDEVICEPRODUCTTOPLUGIN | 49 |
| <i>Synopsis</i> | 49 |
| <i>Prototype</i> | 49 |
| <i>Parameters</i> | 50 |
| <i>Typical return values</i> | 50 |
| <i>Remarks</i> | 50 |
| <i>Support</i> | 50 |
| <i>See Also</i> | 50 |
| 7.3 MP_ASSIGNLOGICALUNITTOTPG..... | 50 |
| <i>Synopsis</i> | 50 |
| <i>Prototype</i> | 50 |
| <i>Parameters</i> | 50 |
| <i>Typical return values</i> | 51 |
| <i>Remarks</i> | 51 |
| <i>Support</i> | 51 |
| <i>See also</i> | 51 |
| 7.4 MP_CANCELOVERRIDEPATH..... | 51 |
| <i>Synopsis</i> | 51 |
| <i>Prototype</i> | 51 |
| <i>Parameters</i> | 51 |
| <i>Typical return values</i> | 51 |
| <i>Remarks</i> | 52 |
| <i>Support</i> | 52 |
| <i>See also</i> | 52 |
| 7.5 MP_COMPAREOIDS | 52 |
| <i>Synopsis</i> | 52 |
| <i>Prototype</i> | 52 |
| <i>Parameters</i> | 52 |
| <i>Typical return values</i> | 52 |
| <i>Remarks</i> | 52 |
| <i>Support</i> | 52 |
| 7.6 MP_DEREGISTERFOROBJECTPROPERTYCHANGES | 52 |
| <i>Synopsis</i> | 52 |

| | |
|---|----|
| <i>Prototype</i> | 53 |
| <i>Parameters</i> | 53 |
| <i>Typical return values</i> | 53 |
| <i>Support</i> | 53 |
| <i>Remarks</i> | 53 |
| <i>See also</i> | 53 |
| 7.7 MP_DEREGISTERFOROBJECTVISIBILITYCHANGES | 53 |
| <i>Synopsis</i> | 53 |
| <i>Prototype</i> | 54 |
| <i>Parameters</i> | 54 |
| <i>Typical return values</i> | 54 |
| <i>Support</i> | 54 |
| <i>Remarks</i> | 54 |
| <i>See also</i> | 54 |
| 7.8 MP_DEREGISTERPLUGIN | 54 |
| <i>Synopsis</i> | 54 |
| <i>Prototype</i> | 55 |
| <i>Parameters</i> | 55 |
| <i>Typical return values</i> | 55 |
| <i>Support</i> | 55 |
| <i>Remarks</i> | 55 |
| <i>See also</i> | 55 |
| 7.9 MP_DISABLEAUTOFAILBACK | 55 |
| <i>Synopsis</i> | 55 |
| <i>Prototype</i> | 55 |
| <i>Parameters</i> | 55 |
| <i>Typical Return Values</i> | 55 |
| <i>Support</i> | 56 |
| <i>See also</i> | 56 |
| 7.10 MP_DISABLEAUTOPROBING | 56 |
| <i>Synopsis</i> | 56 |
| <i>Prototype</i> | 56 |
| <i>Parameters</i> | 56 |
| <i>Typical return values</i> | 56 |
| <i>Support</i> | 56 |
| <i>See also</i> | 56 |
| 7.11 MP_DISABLEPATH | 57 |
| <i>Synopsis</i> | 57 |
| <i>Prototype</i> | 57 |
| <i>Parameters</i> | 57 |
| <i>Typical return values</i> | 57 |
| <i>Support</i> | 57 |
| <i>Remarks</i> | 57 |
| <i>See also</i> | 57 |
| 7.12 MP_ENABLEAUTOFAILBACK | 57 |
| <i>Synopsis</i> | 57 |
| <i>Prototype</i> | 57 |
| <i>Parameters</i> | 57 |
| <i>Typical return values</i> | 58 |

| | |
|--|----|
| <i>Support</i> | 58 |
| <i>See also</i> | 58 |
| 7.13 MP_ENABLEAUTOPROBING | 58 |
| <i>Synopsis</i> | 58 |
| <i>Prototype</i> | 58 |
| <i>Parameters</i> | 58 |
| <i>Typical return values</i> | 58 |
| <i>Support</i> | 58 |
| <i>See also</i> | 59 |
| 7.14 MP_ENABLEPATH | 59 |
| <i>Synopsis</i> | 59 |
| <i>Prototype</i> | 59 |
| <i>Parameters</i> | 59 |
| <i>Typical return values</i> | 59 |
| <i>Support</i> | 59 |
| <i>Remarks</i> | 59 |
| <i>See also</i> | 59 |
| 7.15 MP_FREEOIDLIST | 59 |
| <i>Synopsis</i> | 59 |
| <i>Prototype</i> | 59 |
| <i>Parameters</i> | 59 |
| <i>Typical return values</i> | 60 |
| <i>Remarks</i> | 60 |
| <i>Support</i> | 60 |
| 7.16 MP_GETASSOCIATEDPATHOIDLIST | 60 |
| <i>Synopsis</i> | 60 |
| <i>Prototype</i> | 60 |
| <i>Parameters</i> | 60 |
| <i>Typical return values</i> | 60 |
| <i>Remarks</i> | 60 |
| <i>Support</i> | 61 |
| <i>See also</i> | 61 |
| 7.17 MP_GETASSOCIATEDPLUGINOID | 61 |
| <i>Synopsis</i> | 61 |
| <i>Prototype</i> | 61 |
| <i>Parameters</i> | 61 |
| <i>Typical return values</i> | 61 |
| <i>Remarks</i> | 61 |
| <i>Support</i> | 61 |
| 7.18 MP_GETASSOCIATEDTPGOIDLIST | 61 |
| <i>Synopsis</i> | 61 |
| <i>Prototype</i> | 61 |
| <i>Parameters</i> | 62 |
| <i>Typical return values</i> | 62 |
| <i>Remarks</i> | 62 |
| <i>Support</i> | 62 |
| <i>See also</i> | 62 |
| 7.19 MP_GETDEVICEPRODUCTOIDLIST | 62 |
| <i>Synopsis</i> | 62 |

| | |
|--|----|
| <i>Prototype</i> | 62 |
| <i>Parameters</i> | 62 |
| <i>Typical return values</i> | 63 |
| <i>Remarks</i> | 63 |
| <i>Support</i> | 63 |
| <i>See also</i> | 63 |
| 7.20 MP_GETDEVICEPRODUCTPROPERTIES | 63 |
| <i>Synopsis</i> | 63 |
| <i>Prototype</i> | 63 |
| <i>Parameters</i> | 63 |
| <i>Typical return values</i> | 63 |
| <i>Support</i> | 64 |
| <i>See also</i> | 64 |
| 7.21 MP_GETINITIATORPORTOIDLIST | 64 |
| <i>Synopsis</i> | 64 |
| <i>Prototype</i> | 64 |
| <i>Parameters</i> | 64 |
| <i>Typical return values</i> | 64 |
| <i>Remarks</i> | 64 |
| <i>Support</i> | 65 |
| <i>See also</i> | 65 |
| 7.22 MP_GETINITIATORPORTPROPERTIES | 65 |
| <i>Synopsis</i> | 65 |
| <i>Prototype</i> | 65 |
| <i>Parameters</i> | 65 |
| <i>Typical return values</i> | 65 |
| <i>Support</i> | 65 |
| <i>See also</i> | 65 |
| 7.23 MP_GETLIBRARYPROPERTIES | 65 |
| <i>Synopsis</i> | 65 |
| <i>Prototype</i> | 65 |
| <i>Parameters</i> | 66 |
| <i>Typical return values</i> | 66 |
| <i>Support</i> | 66 |
| <i>See also</i> | 66 |
| 7.24 MP_GETMPLUOIDLISTFROMTPG | 66 |
| <i>Synopsis</i> | 66 |
| <i>Prototype</i> | 66 |
| <i>Parameters</i> | 66 |
| <i>Typical return values</i> | 66 |
| <i>Remarks</i> | 67 |
| <i>Support</i> | 67 |
| <i>See also</i> | 67 |
| 7.25 MP_GETMPLOGICALUNITPROPERTIES | 67 |
| <i>Synopsis</i> | 67 |
| <i>Prototype</i> | 67 |
| <i>Parameters</i> | 67 |
| <i>Typical Return Values</i> | 67 |
| <i>Support</i> | 67 |

| | |
|--|----|
| <i>See also</i> | 67 |
| 7.26 MP_GETMULTIPATHLUS..... | 68 |
| <i>Synopsis</i> | 68 |
| <i>Prototype</i> | 68 |
| <i>Parameters</i> | 68 |
| <i>Typical return values</i> | 68 |
| <i>Remarks</i> | 68 |
| <i>Support</i> | 68 |
| <i>See also</i> | 68 |
| 7.27 MP_GETOBJECTTYPE..... | 68 |
| <i>Synopsis</i> | 68 |
| <i>Prototype</i> | 68 |
| <i>Parameters</i> | 69 |
| <i>Typical return values</i> | 69 |
| <i>Remarks</i> | 69 |
| <i>Support</i> | 69 |
| <i>See also</i> | 69 |
| 7.28 MP_GETPATHLOGICALUNITSTATISTICS..... | 69 |
| <i>Synopsis</i> | 69 |
| <i>Prototype</i> | 69 |
| <i>Parameters</i> | 69 |
| <i>Typical return values</i> | 69 |
| <i>See also</i> | 70 |
| 7.29 MP_GETPATHLOGICALUNITDISTRIBUTEDSTATISTICS..... | 70 |
| <i>Typical return values</i> | 70 |
| <i>See also</i> | 71 |
| 7.30 MP_GETPATHLOGICALUNITPROPERTIES | 71 |
| <i>Synopsis</i> | 71 |
| <i>Prototype</i> | 71 |
| <i>Parameters</i> | 71 |
| <i>Typical return values</i> | 72 |
| <i>Support</i> | 72 |
| <i>See also</i> | 72 |
| 7.31 MP_GETPLUGINOIDLIST..... | 72 |
| <i>Synopsis</i> | 72 |
| <i>Prototype</i> | 72 |
| <i>Parameters</i> | 72 |
| <i>Typical return values</i> | 72 |
| <i>Remarks</i> | 72 |
| <i>Support</i> | 72 |
| <i>See also</i> | 73 |
| 7.32 MP_GETPLUGINPROPERTIES..... | 73 |
| <i>Synopsis</i> | 73 |
| <i>Prototype</i> | 73 |
| <i>Parameters</i> | 73 |
| <i>Typical return values</i> | 73 |
| <i>Support</i> | 73 |
| <i>See also</i> | 73 |
| 7.33 MP_GETPROPRIETARYLOADBALANCEOIDLIST | 73 |

| | |
|--|----|
| Synopsis..... | 73 |
| Prototype | 73 |
| Parameters..... | 73 |
| Typical return values | 74 |
| Remarks..... | 74 |
| Support..... | 74 |
| See also..... | 74 |
| 7.34 MP_GETPROPRIETARYLOADBALANCEPROPERTIES..... | 74 |
| Synopsis..... | 74 |
| Prototype | 74 |
| Parameters..... | 74 |
| Typical return values | 75 |
| Support..... | 75 |
| See also..... | 75 |
| 7.35 MP_GETTARGETPORTGROUPPROPERTIES | 75 |
| Synopsis..... | 75 |
| Prototype | 75 |
| Parameters..... | 75 |
| Typical return values | 75 |
| Remarks..... | 75 |
| Support..... | 76 |
| See also..... | 76 |
| 7.36 <u>MP_GETSUPPORTEDDEVICEPRODUCTCATEGORY</u> | 76 |
| <u>Synopsis</u> | 76 |
| <u>Prototype</u> | 76 |
| <u>Parameters</u> | 76 |
| <u>Typical return values</u> | 76 |
| <u>Remarks</u> | 76 |
| <u>Support</u> | 76 |
| <u>See also</u> | 76 |
| 7.37 MP_GETTARGETPORTOIDLIST..... | 76 |
| Synopsis..... | 76 |
| Prototype | 77 |
| Parameters..... | 77 |
| Typical return values | 77 |
| Remarks..... | 77 |
| Support..... | 77 |
| See also..... | 77 |
| 7.38 MP_GETTARGETPORTPROPERTIES | 77 |
| Synopsis..... | 77 |
| Prototype | 77 |
| Parameters..... | 77 |
| Typical return values | 78 |
| Support..... | 78 |
| See also..... | 78 |
| 7.39 MP_REGISTERFOROBJECTPROPERTYCHANGES | 78 |
| Synopsis..... | 78 |
| Prototype | 78 |
| Parameters..... | 78 |

| | |
|--|----|
| <i>Typical return values</i> | 79 |
| <i>Support</i> | 79 |
| <i>Remarks</i> | 79 |
| <i>See also</i> | 79 |
| 7.40 MP_REGISTERFOROBJECTVISIBILITYCHANGES | 79 |
| <i>Synopsis</i> | 79 |
| <i>Prototype</i> | 79 |
| <i>Parameters</i> | 79 |
| <i>Typical return values</i> | 80 |
| <i>Support</i> | 80 |
| <i>Remarks</i> | 80 |
| <i>See also</i> | 80 |
| 7.41 MP_REGISTERPLUGIN | 80 |
| <i>Synopsis</i> | 80 |
| <i>Prototype</i> | 80 |
| <i>Parameters</i> | 81 |
| <i>Typical return values</i> | 81 |
| <i>Support</i> | 81 |
| <i>Remarks</i> | 81 |
| <i>See also</i> | 81 |
| 7.42 MP_REMOVEDEVICEPRODUCTFROMPLUGIN | 81 |
| <i>Synopsis</i> | 81 |
| <i>Prototype</i> | 81 |
| <i>Parameters</i> | 81 |
| <i>Typical return values</i> | 82 |
| <i>Remarks</i> | 82 |
| <i>Support</i> | 82 |
| <i>See Also</i> | 82 |
| 7.43 MP_SENDSXSICOMMAND | 82 |
| <i>Synopsis</i> | 82 |
| <i>Prototype</i> | 82 |
| <i>Parameters</i> | 83 |
| <i>Typical return values</i> | 83 |
| <i>Support</i> | 84 |
| 7.44 MP_SETDEVICEPRODUCTLOADBALANCETYPE..... | 84 |
| <i>Synopsis</i> | 84 |
| <i>Prototype</i> | 84 |
| <i>Parameters</i> | 84 |
| <i>Typical return values</i> | 84 |
| <i>Remarks</i> | 84 |
| <i>Support</i> | 84 |
| 7.45 MP_SETLOGICALUNITLOADBALANCETYPE | 85 |
| <i>Synopsis</i> | 85 |
| <i>Prototype</i> | 85 |
| <i>Parameters</i> | 85 |
| <i>Typical return values</i> | 85 |
| <i>Remarks</i> | 85 |
| <i>Support</i> | 85 |
| 7.46 MP_SETOVERRIDEPATH | 85 |

| | |
|--|----|
| <i>Synopsis</i> | 85 |
| <i>Prototype</i> | 85 |
| <i>Parameters</i> | 86 |
| <i>Typical return values</i> | 86 |
| <i>Remarks</i> | 86 |
| <i>Support</i> | 86 |
| 7.47 MP_SETPATHWEIGHT | 86 |
| <i>Synopsis</i> | 86 |
| <i>Prototype</i> | 86 |
| <i>Parameters</i> | 86 |
| <i>Typical return values</i> | 87 |
| <i>Support</i> | 87 |
| 7.48 MP_SETPLUGINLOADBALANCETYPE | 87 |
| <i>Synopsis</i> | 87 |
| <i>Prototype</i> | 87 |
| <i>Parameters</i> | 87 |
| <i>Typical return values</i> | 87 |
| <i>Remarks</i> | 88 |
| <i>Support</i> | 88 |
| 7.49 MP_SETFAILBACKPOLLINGRATE..... | 88 |
| <i>Synopsis</i> | 88 |
| <i>Prototype</i> | 88 |
| <i>Parameters</i> | 88 |
| <i>Typical return values</i> | 88 |
| <i>Remarks</i> | 88 |
| <i>Support</i> | 88 |
| <i>See also</i> | 88 |
| 7.50 MP_SETPROBINGPOLLINGRATE | 89 |
| <i>Synopsis</i> | 89 |
| <i>Prototype</i> | 89 |
| <i>Parameters</i> | 89 |
| <i>Typical return values</i> | 89 |
| <i>Remarks</i> | 89 |
| <i>Support</i> | 89 |
| <i>See also</i> | 89 |
| 7.51 MP_SETPROPRIETARYPROPERTIES..... | 89 |
| <i>Synopsis</i> | 89 |
| <i>Prototype</i> | 89 |
| <i>Parameters</i> | 90 |
| <i>Typical return values</i> | 90 |
| <i>Remarks</i> | 90 |
| <i>Support</i> | 90 |
| 7.52 MP_SETTPGACCESS | 90 |
| <i>Synopsis</i> | 90 |
| <i>Prototype</i> | 90 |
| <i>Parameters</i> | 90 |
| <i>Typical return values</i> | 91 |
| <i>Remarks</i> | 91 |
| <i>Support</i> | 91 |

| | |
|---|------------|
| 8 IMPLEMENTATION COMPLIANCE | 91 |
| 9 IMPLEMENTATION NOTES | 92 |
| 9.1 BACKWARDS COMPATIBILITY | 92 |
| 9.2 CLIENT USAGE NOTES..... | 92 |
| 9.2.1 <i>Reserved fields</i> | 92 |
| 9.2.2 <i>Event notification within a single client</i> | 92 |
| 9.2.3 <i>Event notification and multi-threading</i> | 92 |
| 9.3 LIBRARY IMPLEMENTATION NOTES | 92 |
| 9.3.1 <i>Multi-threading support</i> | 92 |
| 9.3.2 <i>Event notification and multi-threading</i> | 92 |
| 9.3.3 <i>Structure packing</i> | 92 |
| 9.3.4 <i>Calling conventions</i> | 93 |
| 9.4 PLUGIN IMPLEMENTATION NOTES | 93 |
| 9.4.1 <i>Reserved fields</i> | 93 |
| 9.4.2 <i>Multi-threading support</i> | 93 |
| 9.4.3 <i>Event notification to different clients</i> | 93 |
| 9.4.4 <i>Event notification and multi-threading</i> | 93 |
| 9.4.5 <i>Event overhead conservation</i> | 93 |
| 9.4.6 <i>Function names</i> | 93 |
| A.1 GENERAL | 94 |
| A.2 INITIATOR PORT OSDEVICENAME | 94 |
| A.3 LOGICAL UNIT OSDEVICENAME | 94 |
| D.1 GENERAL | 99 |
| D.2 EXAMPLE OF GETTING LIBRARY PROPERTIES | 99 |
| D.3 EXAMPLE OF GETTING PLUGIN PROPERTIES | 99 |
| D.4 EXAMPLE OF DISCOVERING PATH LUS ASSOCIATED WITH AN MP LU..... | 100 |
| D.5 EXAMPLE OF GETTING STATISTICS ON A PATH LOGICAL UNIT | 101 |
| D.6 EXAMPLE OF GETTING DISTRIBUTED STATISTICS ON A PATH LOGICAL UNIT... | 102 |
| FIGURE 1 - ASYMMETRIC ARRAY EXAMPLE | 22 |
| FIGURE 2 - API INSTANCES CORRESPONDING TO ASYMMETRIC ARRAY EXAMPLE | 23 |
| FIGURE 3 - RELATIONSHIP BETWEEN VARIOUS OBJECTS IN THE MULTIPATH MODEL | 26 |
| FIGURE 4 - DRIVER REPRESENTATION OF A LOGICAL UNIT WITH MULTIPLE PATHS..... | 27 |
| FIGURE 5 - APIS RELATIVE TO THE OBJECTS FROM FIGURE 1 | 52 |
| TABLE A.2 - NAMES FOR THE OSDEVICENAME | 91 |
| FIGURE B.1 - SYNTHETIC TARGET PORT GROUPS | 92 |

INFORMATION TECHNOLOGY – MULTIPATH MANAGEMENT API

1 Scope

This standard provides management interfaces to standard capabilities defined in ISO/IEC 14776-453 (SPC-3) and common vendor-specific extensions to the standard capabilities. The intended audience is vendors that deliver drivers that provide these capabilities. This standard relates to SCSI multipathing features and excludes multipathing between interconnect devices (such as Fibre Channel switches) and transport specific multipathing (such as iSCSI multiple connections per session).

2 Normative references

The following standards contain provisions which, through reference in this text, constitute provisions of this standard. All standards are subject to revision, and parties to agreements based on this standard are encouraged to investigate the possibility of applying the most recent editions of the standards indicated below.

ISO/IEC 14776-150, *Information technology – Small Computer System Interface (SCSI) – Part 150: Serial Attached SCSI (SAS)*

ISO/IEC 14776-413, *Information technology – Small Computer System Interface (SCSI) – Part 413: SCSI Architecture Model - 3 (SAM-3)*

ISO/IEC 14776-453, *Information technology – Small Computer System Interface (SCSI) – Part 453: Primary Commands - 3 (SPC-3)*

ISO/IEC 14776-115, *Information technology – Small Computer System Interface (SCSI) – Part 115: Parallel Interface - 5 (SPI-5)*

ISO/IEC 14165-251, *Information technology – Fibre Channel (FC) – Part 251: Framing and Signaling (FC-FS)*

ISO/IEC 14165-133, *Information technology – Fibre Channel (FC) – Part 113: Switch Fabric - 3 (FC-SW-3)*

ISO/IEC 9899:1999, *Programming languages – C*

RFC 3720, Internet Small Computer Systems Interface (iSCSI)

NOTE - Copies of IETF standards may be obtained through the Internet Engineering Task Force (IETF) at <http://www.ietf.org>.

OMG Unified Modeling Language (UML) Specification Version 1.5, March 2003

NOTE - For more information on the UML specification, contact the Object Modeling Group at <http://www.omg.org>.

3 Terms, definitions and abbreviations

3.1 Terms and definitions

For the purposes of this document the following terms and definitions apply.

auto-failback

capability of some multipath drivers to resume use of a path when the path transitions from unavailable to available

auto-probing

capability of some multipath drivers to validate operational paths that are not currently being used

available paths

set of paths for a logical unit that may be considered for routing I/O requests

NOTE For symmetric access devices, all paths are considered *available*. For asymmetric access devices, all paths in active target port groups are considered *available*.

device file

operating system files (for instance UNIX, Linux etc.) that facilitate communication with the system's hardware and peripherals

Device Identification VPD page

VPD page that provides the means to retrieve identification information about the SCSI device, logical unit, and SCSI port

hexadecimal-encoded binary data

ASCII character string used to denote the hexadecimal encoding of a binary string of octets

NOTE It may only contain the ASCII characters 0-9, A-F, and a-f. Two hexadecimal characters represent each byte of binary data.

host

compute node connected to the SAN

initiator

SCSI device that initiates requests; also known as a client

NOTE In this document, initiator refers to an initiator port.

logical unit

addressable entity within a SCSI target

NOTE For example, RAID arrays expose each virtual disk volume as a logical unit. When the term "logical unit: is used in this standard and is not qualified as a "multipath logical unit" or "path logical unit", it refers to a logical unit in a target device.

multipath logical unit

an object type of this API representing a “virtual “logical unit that coalesces multiple path logical units for the same underlying device logical unit

object ID

unique identifier assigned to any object within the MP API

NOTE Objects sometimes represent physical entities, e.g. initiator ports. At other times, objects represent logical entities, e.g. target port groups.

path

association between an initiator port, target port and logical unit, see 0

path logical unit

an object type of this API providing access to a single logical unit through a single initiator port and single device port

NOTE Within this API, each path (see 0) is modelled as a path logical unit. The result of multipath drivers is a single OS device file representing a multipath logical unit aggregating multiple path logical units.

persistent

quality of something being non-volatile

NOTE This usually means that the associated data is recorded on some non-volatile medium such as flash RAM or magnetic disk and that the data survives beyond system reboots. Implicitly, the data is readable from the non-volatile medium.

NOTE Examples of persistent storage:

- under Windows, the registry would be a common place to find persistently stored values (assuming that the values are not stored as volatile);
- under any OS a file on magnetic hard disk would be persistent.

plugin

software, written for an OS, HBA or device vendor that provides support for one or more multipath drivers

NOTE The plugin's job is to provide a bridge between the library's interface and the vendor's multipath driver. A plugin is typically a loadable module, for instance, a DLL in Windows and a shared object in UNIX. A plugin is accessed by an application through the Multipath Management API library.

product (or device product)

a particular model of target device, identified by the vendor, product and revision IDs returned in the standard SCSI INQUIRY command response

target

SCSI device containing logical units and SCSI target ports that receives commands from a SCSI initiator

target port group

set of target ports that are in the same target port access state at all times

unicode

system of uniquely identifying (numbering) characters such that nearly any character in any language is identified.

VPD

vendor specific information about a device returned in response to a SCSI INQUIRY command with the EVPD bit set (see SPC-3)

3.2 Abbreviations

| | |
|-----|-----------------------------------|
| API | application programming interface |
| DLL | dynamic link library |
| HBA | host bus adapter |
| LUN | logical unit number |
| OID | object identifier |
| OS | operating system |
| UML | Unified Modeling Language |
| UTF | Unicode Transformation Format |
| VPD | vital product data |

4 Document conventions

The API is specified as a set of types and structures (see Clause 6) followed by a set of function definitions (see Clause 7). This clause discusses the formats used in these clauses along with conventions used in defining the API.

Constants are defined as a list of #defines followed by a typedef for a C integer type. C language enums do not have a specific size; using #defines rather than enums helps assure client code is interoperable across platforms and compilers – especially if used in C++ applications.

API description format

Each API's description is divided into seven subclauses.

1 Synopsis

This subclause gives a brief description of what action the API performs.

2 Prototype

This subclause gives a prototype of the function in a format that is a combination of a C function prototype and an Interface Definition Language (IDL) prototype. The prototypes show the following:

- the name of the API;
- the return type of the API;
- each of the parameters of the API, the type of each parameter, and whether that parameter is an input parameter, output parameter, or both an input and an output parameter.

3 Parameters

This subclause lists each parameter along with an explanation of what the parameter represents.

4 Typical return values

This subclause lists the Typical Return Values of the API with an explanation of why a particular return value would be returned. It is important to note that this list is not a comprehensive list of all of the possible return values. There are certain errors, e.g. MP_STATUS_INSUFFICIENT_MEMORY, which might be returned by any API.

5 Remarks

This subclause contains comments about the API that may be useful to the reader. In particular, this subclause contains extra information about the information returned by the API.

6 Support

This subclause states that if an API is mandatory to be supported, optional to be supported, or mandatory to be supported under certain conditions.

- If an API is mandatory to be supported a client can rely on the API functioning under all circumstances.
- If the API is optional to be supported then a client cannot rely on the API functioning.
- If the API is mandatory to be supported under certain conditions then a client can rely on the API functioning if the specified conditions are met. Otherwise a client should assume that the API is not supported.

7 See also

This subclause lists other related APIs or related code examples that the reader might find useful.

5 Background technical information

5.1 Overview

Open system platforms give applications access to physical devices by presenting a special set of file names that represent the devices. Although end users typically don't use these special device files, knowledgeable applications (file systems, databases, backup software) operate on these device files and provide familiar user interfaces to storage. The device files have a hierarchical organization, either by using files and directories or by naming conventions.

This hierarchy of device files (sometimes called a device tree) provides an effective interface for simpler, desktop device configurations. Inside open systems kernels, the hierarchy is exploited to allow different drivers to operate on different parts of the device tree. When the OS discovers connected devices and builds the device tree, multiple paths to the same device may show up as separate device files in the device tree. Separate storage applications using device files that represent paths to the same device will overwrite each other's data.

As storage products (typically disk arrays) strove for better reliability and performance, they added multipath support. For OSes that lacked multipath support, the device and logical volume manager vendors provided multipath drivers. Device standards lacked standard interfaces for identifying multipath devices; so multipath drivers are often limited to specific device products. Recently standards have been defined and OS vendors have started integrating multipath support in their bundled drivers.

These drivers create special device files that represent multipath devices. Storage applications like file systems can use these multipath device files the same way they would use a single-path device file, but benefit from improved reliability and performance. In addition, the multipath drivers provide some management capabilities, for example, failover or load balancing, that only apply to multipath devices.

This standard focuses on devices accesses through SCSI commands. SCSI commands are sent to a target device by an initiator. The target may consist of multiple logical units. For example, a

RAID array exposes virtual disk as separate logical units. A target device supporting multiple paths and attached hosts will nearly always have multiple ports. Each permutation of initiator port, target port and logical unit is commonly referred to as a path. With no multipath support in place, the OS would see each path as separate logical units. The function of multipath drivers is then to create a virtual multipath device that aggregates all these path logical units.

5.2 Target port groups

A logical unit may only be accessible through certain target ports. If the device supports asymmetric access (see 5.3.2), certain ports may be preferred for access (sometimes this is referred to as affinity). ISO/IEC 14776-453 (SPC-3) has introduced target port groups as a way for target devices to represent access characteristics for logical units. A target port group is a collection of ports. All the logical units associated with that target port group share the same access state (active/optimized, active/non-optimized, standby or unavailable).

Target port groups are abstract elements that may or may not equate to an element of the target system (such as a controller).

The concept of target port groups can be applied to all devices, even if they don't actually implement the SCSI standard interfaces. This API does not require an SPC-3-compliant array; it includes target port groups and uses the terminology of ISO/IEC 14776-453 (SPC-3) as a starting point, but is extended to reflect common vendor implementations.

In order to simplify tasks for client software, all plugins/drivers make it appear that the underlying hardware uses target port group interfaces. For example, consider an asymmetric array with two ports where each port is primary (optimized) for half the logical units. The plugin/driver would create four "virtual" target port groups; each logical unit would be part of two target port groups, one with optimized access state for its primary controller and one with non-optimized access state for the secondary controller. See *Annex B* for more details.

5.3 Relationship between target port groups in SCSI and in this API

5.3.1 General

This subclause describes the relationship between the interfaces defined in ISO/IEC 14776-453 (SPC-3) and this API related to target port groups.

The SCSI Device Identification VPD page (i.e., page 83h) and REPORT TARGET PORT GROUPS command allow initiators to discover the target port group configuration.

- Device Identification VPD page returns a list of identifiers. These include:
 - **relative target port identifier** – a two-byte value with a target-unique ID for the target port the INQUIRY is sent to. In this API, this is the relativePortID property in MP_TARGET_PORT_PROPERTIES;
 - **target port group identifier** – a two-byte value with a target-unique ID for the target port group. In this API, this is the tpgID property of MP_TARGET_PORT_GROUP_PROPERTIES.
- The REPORT TARGET PORT GROUPS command returns a list of target port groups, with access state, and the list of relative port IDs of target ports that comprise each target port group. The access state corresponds to this API's MP_ACCESS_STATE_TYPE and MP_TARGET_PORT_GROUP accessState property.

The SCSI SET TARGET PORT GROUPS command allows an initiator to set target port access state – which causes failover or failback. This API provides MP_SetTPGAccess as an interface to SET TARGET PORT GROUPS.

For a concrete example, Figure 1 depicts a RAID array with asymmetric access and two controllers. Each controller contains two ports that always share the same access state. The RAID configuration is set up with four logical units. Optimally each pair of logical units is accessed through the ports on different controllers. In case either controller fails, all four logical units can be accessed through the ports in the alternate controller.

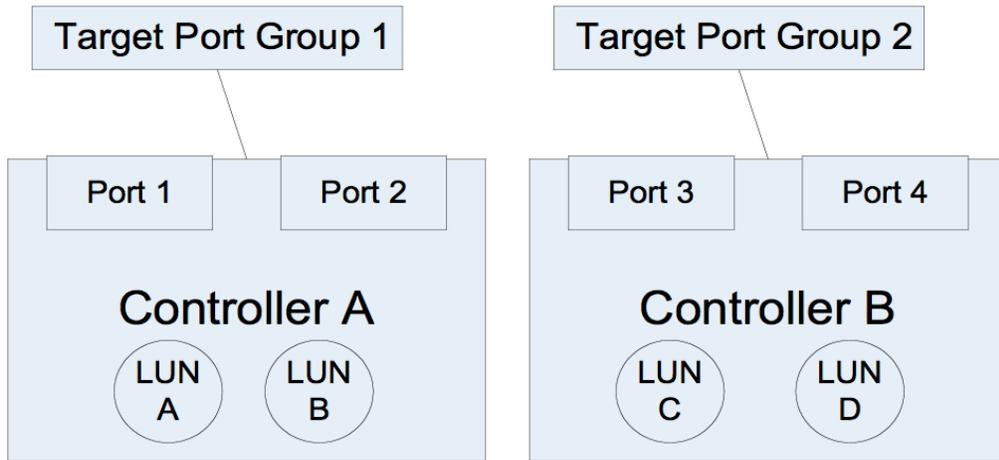

Figure 1 – Asymmetric array example

The table below summarizes the information returned for this array configuration in the SCSI INQUIRY identifiers and REPORT TARGET PORT GROUPS command response.

| Logical unit | Access from port 1 or 2 | Access from port 3 or 4 |
|--------------|-------------------------|-------------------------|
| | TPG ID / State | TPG ID / State |
| A | 1 / Active optimized | 2 / Standby |
| B | 1 / Active optimized | 2 / Standby |
| C | 1 / Standby | 2 / Active optimized |
| D | 1 / Standby | 2 / Active optimized |

In case of a failure condition of controller A, all logical units as accessed from port 1 or 2 will either see lack of response or a TPG access state of unavailable. Logical units A and B as seen through ports 3 or 4 will see an access state of active non-optimized.

Note that the target port group access states for a given target port group ID differs depending on which port the REPORT TARGET PORT GROUP command is issued to. In this API, each target port group ID and access state permutation is modelled as a different instance of a target port group class. The figure below is an instance diagram representing the API instances corresponding to this same asymmetric array described above. The relevant API properties are also included.

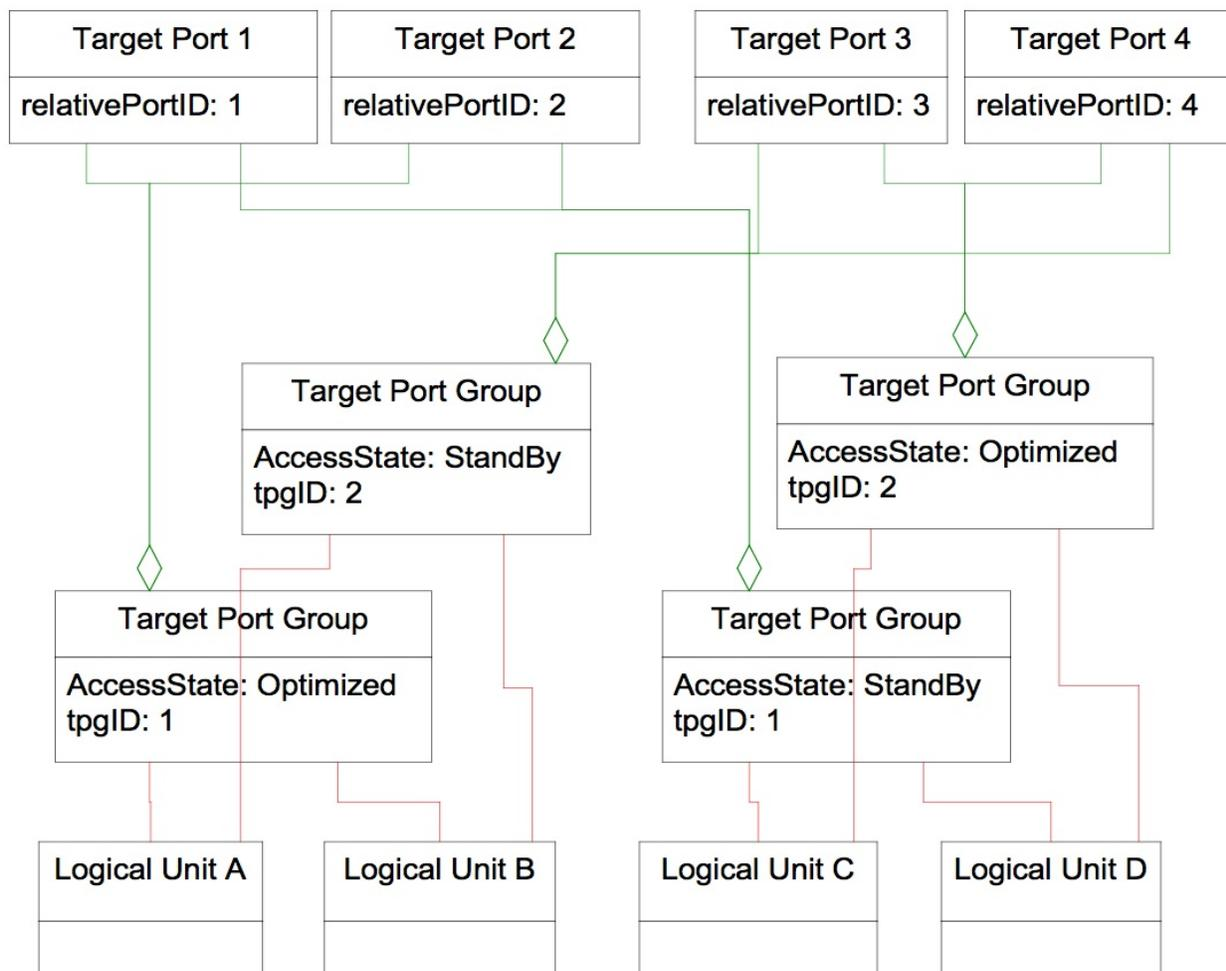

Figure 2 – API Instances corresponding to asymmetric array example

5.3.2 Symmetric and asymmetric multipath access

A multipath device may have symmetric or asymmetric access. There may be a performance cost when host drivers switch between asymmetric paths. Symmetric access devices avoid that penalty. One common asymmetric configuration is a RAID array where access to a particular logical unit is optimal through one device port and non-optimal through the other port. ISO/IEC 14776-453 (SPC-3) includes standard interfaces for discovery and management of multipath devices.¹ In addition to standardization of logical unit identifiers and a failover command, ISO/IEC 14776-453 (SPC-3) has interfaces that allow a target device to describe target port groups. All the ports in a target port group share an access state that is either optimal or non-optimal.

Setting the access state to active/optimized in all target ports groups associated with a logical unit indicates symmetric access. A target system where all logical units have symmetric access

¹ Although this API provides interfaces for discovery of multipath devices, it only provides information available through installed plugins. If a client applications requires comprehensive discovery of all devices, it should also use platform-specific device discovery APIs.

from all ports could be described with a single target port group with access state active/optimized associated with all logical units and target ports.

A logical unit could have symmetric access through some, but not all ports. The optimal ports can be used for load balancing, but the non-optimal ports should only be used for failover. This would be modelled with target port groups with multiple associated ports and access state set to active/optimized.

5.3.3 Logical unit affinity groups

Some target devices (particularly RAID arrays) have groups of logical units that failover/failback as a group. In other words, when one logical units' target port group access state changes, the access state of the other logical units in the group also changes. ISO/IEC 14776-453 (SPC-3) has a simple interface to discover these groups; the Device Identification VPD page response may include a logical unit group identifier (identifier type 6h). All the logical units that expose the same logical unit group identifier are members of the same logical unit group. A logical unit may only be a member of a single logical unit group.

This API follows the same approach; `MP_MULTIPATH_LOGICAL_UNIT_PROPERTIES` has a property `logicalUnitGroupID`. The details for this property (see 6.27) specify how a plugin/driver sets this property if the target device does not support the SCSI interface.

This API does not provide a mechanism to create a logical unit group or add members. ISO/IEC 14776-453 (SPC-3) does not provide this capability. In some implementations, the logical unit groups are artefacts of other target capabilities. For example, the logical unit groups in some arrays follow the RAID topology of the configuration of snapshots. Due to the overlap with these other target features, no interfaces for modification are provided in this API.

5.3.4 Load balancing

5.3.4.1 General

This API includes four interfaces that influence load balancing.

- When multiple paths are available with the same access state, each individual I/O request can only be issued to one specific path. Multipath drivers may allow the administrator to select an **algorithm** used to determine which path is selected.
- Some drivers allow the administrator to select a subset of available paths as most preferred; assuming no errors are encountered, I/Os are restricted to the preferred paths. But the non-preferred paths are not necessarily taken off-line; if the preferred paths become not-available, the non-preferred paths may be used as a fallback. This capability is implemented entirely in the host drivers and is independent of target port groups. Some drivers allow multiple levels of preferences, referred to as **administrative weights** in this API.
- Drivers may also allow an administrator to specify an **override path**, a path that is temporarily used for all I/O.
- Drivers may also allow an administrator to **disable a path**, make a path temporarily unavailable for load balancing.

The subclauses below describe these interfaces in more detail.

5.3.4.2 Load balancing algorithms

The API allows a plugin/driver to advertise multiple load balance algorithms that an API client can offer to the administrator. Several common algorithms are defined in `MP_LOAD_BALANCE_TYPE`. The plugin/driver can extend this list with driver-specific algorithms. The API treats these proprietary algorithms opaquely, but provides a mechanism for the plugin/driver vendor to expose a vendor and algorithm name to client applications. A client could use these names to populate a "pull-down" list of load balance algorithms that includes vendor-specific algorithms.

Some multipath drivers have load-balancing algorithms optimized for certain device types. The device type is determined by the vendor and product IDs returned in the SCSI Inquiry data. A

plugin/driver can report its list of supported device types using MP_DEVICE_PRODUCT_PROPERTIES.

5.3.4.3 Administrative preference – path weight

Path weight is a value assigned by an administrator specifying a preference to assign to a path (or path logical unit). The drivers will actively use all available paths with the highest weight (see below for clarification of available). This allows an administrator to assign a subset of available paths for load balanced access and reserve the others as backup paths. For symmetric access devices, all paths are considered available. For asymmetric access devices, all paths in active target port groups are considered available.

The range of weights (maximumWeight) supported by the driver is exposed to clients as a plugin/driver property. A driver with no path weight capabilities should set this property to zero. A driver with the ability to enable/disable paths should set this property to 1. Plugins/drivers with more weight settings can set the property appropriately.

Path weight has precedence over driver policy regarding path selection. In other words, if the drivers understand that a path with a lower weight may be optimal, they should still limit routing to paths the administrator has assigned the highest weight.

Other APIs may impact I/O routing (MP_DisablePath, MP_EnablePath, MP_SetOverridePath, MP_SetTPGAccess) but no other API changes the actual weight values. This approach allows an administrator to define long-term policy using path weights and temporarily to override this policy in order to address hardware failures, run diagnostic tests or quiesce hardware.

The default weight (prior to being set by the administrator) is the plugin/driver's maximumWeight value.

Path weight shall be persisted by the plugin/driver.

Example:

A host has four paths to a LUN on a device with asymmetric access; in the normal case, paths one and two are active and paths three and four are in standby state. The administrator would prefer that:

- during non-failover periods, I/O should be through path 1;
- if an HBA failure impacts path 1, but the device is not in a failover state, then path 2 should be used; and
- if the device is in failover state (making paths 1 and 2 unusable) and all HBAs are functioning, then path three should be used.

To configure these preferences, the administrator would assign weight 2 to paths one and three and weight 1 to paths two and four. Actually, the value of the weights is not important as long as the weights assigned to paths one and three are higher than those assigned to paths two and four, respectively.

5.3.4.4 Disable load balancing – override path

The plugin/driver may optionally provide an interface (MP_SetOverridePath) for an override path. An override path is a single path that the administrator can specify for all I/O to a logical unit. Setting a preferred path will disable load balancing. Path weights are not changed when a path is overridden.

5.3.4.5 Disable path

The plugin/driver may optionally provide an interface (MP_DisablePath) to disable a path. Disabling a path makes it ineligible for load balancing in the future, but it may stay in use while the drivers migrate activity to a different path. Path weights are not changed when a path is disabled.

5.3.5 Model overview

The model for this API contains the following classes:

- **Library** – the client library interface that front ends all the plugins;
- **Device product** – information about a specific device supported by the driver;
- **Plugin** – the driver-specific library implementing this API;
- **Proprietary load balance types** – vendor name and description for driver-specific load balance algorithms; opaque to the API, provides algorithm names to applications;
- **Initiator port** – a port on the system hosting the plugin;
- **Target port** – a port on the device;
- **Path logical unit** – represents a single initiator/target port combination accessing a logical unit. May not have a corresponding OS device file name;
- **Multipath logical unit** – the virtual device the aggregates all paths (path logical units) referencing the same logical unit; and
- **Target port group** – a set of target ports that share a common access state.

Figure 3 is a UML diagram that shows the relationship between the various classes of objects in the Multipath model.

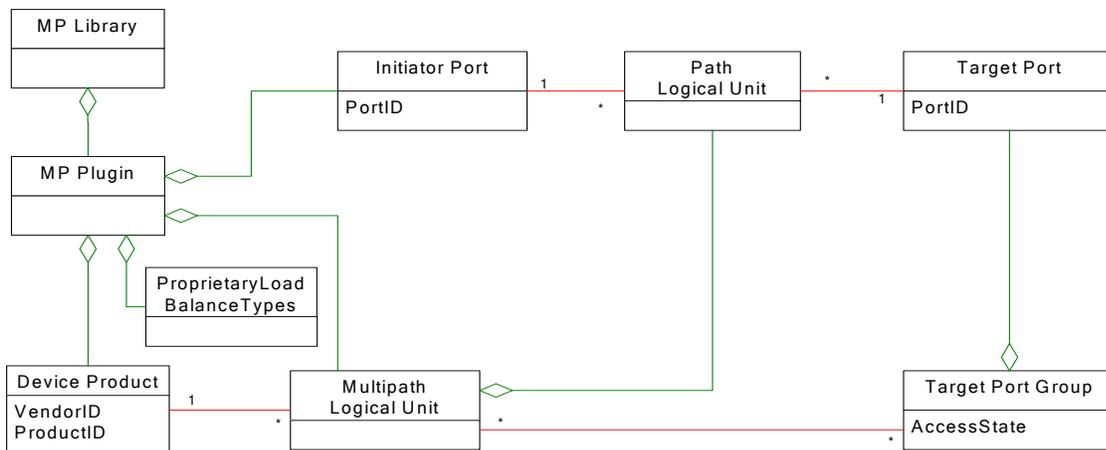

Figure 3 – Relationship between various objects in the multipath model

The structures and APIs defined below allow a client to navigate this model in order to discover and manipulate multipath drivers and hardware. Each class in the diagram has a structure containing properties (for example, MP_INITIATOR_PORT_PROPERTIES has properties for an initiator port) and an API to get the properties (MP_GetInitiatorPortProperties). Other APIs exist to allow the client to follow the associations in the diagram above. For example, the rightmost vertical line represents an aggregation of target ports in a target port group; MP_GetTargetPortOidList returns a list of target port OIDs (OIDs act something like pointers, see 5.7.3). Other APIs change behavior by setting specific properties or by operating on groups of objects.

Figure 4 below is a UML instance diagram that depicts the OS/driver view of a configuration with four paths connected to the same logical unit (for example, a RAID volume). Two initiator ports are connected to separate pairs of target ports, one optimized and one non-optimized, for the particular logical unit. The model depicts the typical MP driver behavior of treating the multipath logical unit as an aggregation of non-MP device files rather than an aggregation of paths.

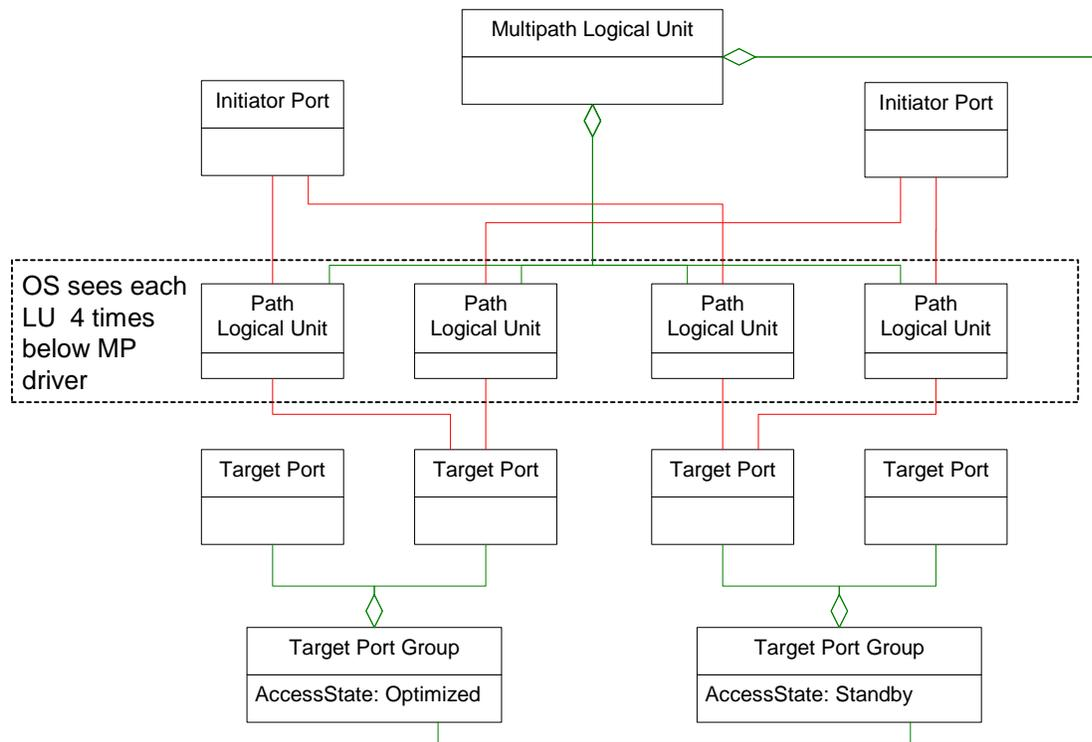

Figure 4 – Driver representation of a logical unit with multiple paths

Note that class/structure instances are not shared across plugin/drivers. But instances in separate plugin/drivers may map to the same “real world” object. For example, multiple plugin/drivers may represent the same initiator (HBA) port. A client would determine these ports are the same by comparing the port name (for example, FC Port WWN) properties of the port instances from the different plugin/drivers.

Installation and configuration of multipath drivers can be complex and hazardous. In some cases, overlap between plugin/drivers could represent configurations that may be catastrophic for a customer. This API does not enforce “best practices”. It assumes that the customer has installed drivers in a “safe” manner. This API just reports on, and manipulates, the configuration.

5.4 Client discovery of optional behavior

5.4.1 General

Without multipath drivers, it’s usually straightforward to get a list of all the disks attached to a system; usually this is just a list of all the device files with names indicating they are disks. But with MP drivers installed, it may be difficult to determine which device files are subsumed by a virtual multipath device. And the multipath driver may add additional special names to the list of disk devices. The primary objective of this API is to create a deterministic way for management software to discover the storage resources attached to a server.

In addition to the discovery functions, this API also provides functions for active management of multipath drivers, functions to control failover/failback and load balancing. These active management APIs are optional.

In general, support for optional behavior is exposed through properties of plugin/drivers (and other objects). For example, MP_PLUGIN_PROPERTIES has a property canActivateTPGs that informs a client whether this plugin supports failover/failback commands.

5.4.2 Discovery of load balancing behavior

This API has built-in support for common load balancing algorithms, but also allows plugins to describe proprietary algorithms. These are simply exposed as opaque information that a client can display or modify and are not actually interpreted by the API.

The client can determine the available load balance algorithms by looking at the `supportedLoadBalanceTypes` property of `MP_PLUGIN_PROPERTIES` returned by `MP_GetPluginProperties`. If `MP_LOAD_BALANCE_TYPE_PRODUCT` is set in `supportedLoadBalanceTypes`, then the client should also use `MP_GetDeviceProductOidList` and `MP_GetDeviceProductProperties` to get a list of target product types supported by the plugin. If there is an `MP_DEVICE_PRODUCT_PROPERTIES` instance with the same vendor, product and revision IDs as a specific logical unit, then the `supportedLoadBalanceTypes` property in that `MP_DEVICE_PRODUCT_PROPERTIES` instance override the plugin-wide `supportedLoadBalanceTypes`.

The client can determine the current load balance algorithm for a specific logical unit by looking at the `currentLoadBalanceType` property of `MP_MULTIPATH_LOGICAL_UNIT_PROPERTIES` returned by `MP_GetMPLogicalUnitProperties`.

The client can set the load balance algorithm for a specific logical unit using `MP_GetMPLogicalUnitProperties` and specifying a value other than `MP_LOAD_BALANCE_TYPE_UNKNOWN` for `currentLoadBalanceType`. `MP_LOAD_BALANCE_TYPE_PRODUCT` is only valid if vendor, product and revision from `MP_GetMPLogicalUnitProperties` match those in an instance of `MP_DEVICE_PRODUCT_PROPERTIES` returned by `MP_GetDeviceProductProperties`.

The client can set a plugin-wide default using `MP_SetPluginLoadBalanceType`.

For example, imagine an MP driver from Yoyodyne Corporation supports the following load balancing algorithms:

- round robin (the default);
- least IO;
- two algorithms created by the driver-writers for any device types (known as YY1 and YY2);
- an algorithm for one particular array model (the Acme 3500 array); and
- the YY1 algorithm is not supported for Acme 3500 logical units.

The driver does not allow the administrator to set different load balance types for different logical units on a target.

There should be 1 instance of `MP_PLUGIN_PROPERTIES` with the following flags set in `supportedLoadBalanceTypes`:

| | | |
|--|--------|--------|
| <code>MP_LOAD_BALANCE_ROUNDROBIN</code> | 2 | 2h |
| <code>MP_LOAD_BALANCE_TYPE_LEASTIO</code> | 8 | 8h |
| <code>MP_LOAD_BALANCE_TYPE_PRODUCT</code> | 16 | 10h |
| <code>MP_LOAD_BALANCE_TYPE_PROPRIETARY1</code> | 65536 | 10000h |
| <code>MP_LOAD_BALANCE_TYPE_PROPRIETARY2</code> | 131072 | 20000h |

The value of `supportedLoadBalanceTypes` of `MP_PLUGIN_PROPERTIES` in hex would be 3001ah (the sum of these load balance type flags).

The value of `defaultLoadBalanceType` in `MP_PLUGIN_PROPERTIES` would be `MP_LOAD_BALANCE_ROUNDROBIN`.

There will be an instance of `MP_PROPRIETARY_LOAD_BALANCE_PROPERTIES` for each flag 65536 and up. This object has three fields, the index from above, a name for the algorithm and a name for the vendor. So in this example, we'll have of these objects:

Multipath Management API SNIA Technical Position
Version 1.1

- 65536, “YY1”, “Yoyodyne Corp.”
- 131072, “YY2”, “Yoyodyne Corp.”

Since MP_LOAD_BALANCE_TYPE_PRODUCT is set, there will also be an instance of MP_DEVICE_PRODUCT_PROPERTIES for each device with special driver load support. In this example, there will be one instance with vendor set to “ACME”, product set to “3500”, and revision set to four nulls (this driver supports all revisions of the ACME 3500). The supportedLoadBalanceTypes for Acme 3500 will be set to 2001ah – the same as the plugin-wide supportedLoadBalanceTypes but without the bit for the YY1 algorithm.

Any logical unit on an Acme 3500 array can have currentLoadBalanceType in MP_MULTIPATH_LOGICAL_UNIT_PROPERTIES set to any of the four load balance types in the table above.

Any logical unit of non-Acme-3500 targets can have currentLoadBalanceType set to any of these load balance types other than MP_LOAD_BALANCE_TYPE_PRODUCT.

5.4.3 Client discovery of failover/failback capabilities

Failover only applies to asymmetric access devices. A client can discover whether a logical unit is on an asymmetric access device by looking at the MP_MULTIPATH_LOGICAL_UNIT.asymmetric property.

MP_MULTIPATH_LOGICAL_UNIT.canActivateTPGs indicates support for the MP_ActivateTPGs API – this API provides manual failover capabilities.

5.4.4 Client discovery of a driver’s OS device file name behavior

Some multipath drivers leave the underlying OS device file names (those representing path logical units) on this system. This behavior can be tested with MP_PLUGIN_PROPERTIES.exposesPathDeviceFiles. If exposesPathDeviceFiles is set to false, then the plugin will only expose a single device file name for a multipath logical unit.

If MP_PLUGIN_PROPERTIES.exposesPathDeviceFiles is true, then multiple device file names are available for a multipath logical unit, one for each path.

Some multipath drivers create OS Device Files in non-standard locations. This behavior can be tested with MP_PLUGIN_PROPERTIES.deviceFileNamespace. If this property is null, the device file names associated with the plugin/driver match the “usual” platform names as documented in A.3. If deviceFileNamespace is non-null it is a simple regular expression describing the format for device file names, documented in the deviceFileNamespace property of MP_PLUGIN_PROPERTIES (see 6.24).

5.4.5 Client discovery of auto-failback capabilities

Auto-failback is a capability of some multipath drivers to resume use of a path when the path transitions from unavailable to available. In some cases, this is accomplished with polling (the driver attempts I/Os on unavailable paths).

MP_PLUGIN_PROPERTIES.autoFailbackSupport describes the driver's support for auto-failback. MP_AUTOFAILBACK_SUPPORT_PLUGIN indicates auto-failback is managed the same across all devices. MP_AUTOFAILBACK_SUPPORT_MPLU indicates auto-failback settings are set separately for each multipath logical unit. MP_AUTOFAILBACK_SUPPORT_PLUGINANDMPLU indicates that the both global and per-multipath logical unit settings are supported.

If autoFailbackSupport is either MP_AUTOFAILBACK_SUPPORT_PLUGIN or MP_AUTOFAILBACK_SUPPORT_PLUGINANDMPLU, then these plugin properties are defined:

pluginAutofailbackEnabled

True if the administrator has requested that auto-failback be enabled for all paths accessible via this plugin

failbackPollingRateMax

The maximum polling rate (in seconds) supported by the driver. Zero (0) indicates the driver either does not poll for auto-failback or has not provided an interface to set the polling rate.

currentFailbackPollingRate

The current polling rate (in seconds) for auto-failback. This cannot exceed failbackPollingRateMax.

If autoFailbackSupport is either MP_AUTOFAILBACK_SUPPORT_MPLU or MP_AUTOFAILBACK_SUPPORT_PLUGINANDMPLU, then these multipath logical unit (MP_MULTIPATH_LOGICAL_UNIT_PROPERTIES) properties are defined:

autofailbackEnabled

MP_TRUE if the administrator has requested that auto-failback be enabled for this multipath logical unit. If the plugin's autoFailbackSupport is MP_AUTOFAILBACK_SUPPORT_PLUGINANDMPLU, MP_UNKNOWN is valid and indicates that multipath logical unit has auto-failback enabled if pluginAutofailbackEnabled is true.

failbackPollingRateMax

The maximum polling rate (in seconds) supported by the driver. Zero (0) indicates the driver either does not poll for auto-failback or has not provided an interface to set the polling rate for multipath logical units. If this property and the plugin's failbackPollingRateMax are non-zero, this value has precedence for the associate logical unit.

currentFailbackPollingRate

The current polling rate (in seconds) for auto-failback. This cannot exceed failbackPollingRateMax. If this property and the plugin's currentFailbackPollingRate are non-zero, this value has precedence for the associate logical unit.

5.4.6 Client discovery of auto-probing capabilities

Auto-probing is an optional capability to validate operational paths that are not currently being used.

MP_PLUGIN_PROPERTIES.autoProbingSupport describes the driver's support for auto-probing. MP_AUTOPROBING_SUPPORT_PLUGIN indicates auto-probing is managed the same across all devices. MP_AUTOPROBING_SUPPORT_MPLU indicates auto-probing settings are set separately for each multipath logical unit. MP_AUTOPROBING_SUPPORT_PLUGINANDMPLU indicates that the both global and per-multipath logical unit settings are supported.

If autoProbingSupport is either MP_AUTOPROBING_SUPPORT_PLUGIN or MP_AUTOPROBING_SUPPORT_PLUGINANDMPLU, then these plugin properties are defined:

pluginAutoProbingEnabled

True if the administrator has requested that auto-probing be enabled for all paths accessible via this plugin

probingPollingRateMax

The maximum polling rate (in seconds) supported by the driver. Zero (0) indicates the driver either does not poll for auto-probing or has not provided an interface to set the polling rate.

currentProbingPollingRate

The current polling rate (in seconds) for auto-probing. This cannot exceed probingPollingRateMax.

If autoProbingSupport is either MP_AUTOPROBING_SUPPORT_MPLU or MP_AUTOPROBING_SUPPORT_PLUGINANDMPLU, then these multipath logical unit properties are defined:

autoProbingEnabled

MP_TRUE if the administrator has requested that auto-probing be enabled for this multipath logical unit. If the plugin's autoProbingSupport is MP_AUTOPROBING_SUPPORT_PLUGINANDMPLU, MP_UNKNOWN is valid and indicates that multipath logical unit has auto-probing enabled if pluginAutoProbingEnabled is true.

probingPollingRateMax

The maximum polling rate (in seconds) supported by the driver. Zero (0) indicates the driver either does not poll for auto-probing or has not provided an interface to set the polling rate for multipath logical units. If this property and the plugin's probingPollingRateMax are non-zero, this value has precedence for the associate logical unit.

currentProbingPollingRate

The current polling rate (in seconds) for auto-probing. This cannot exceed probingPollingRateMax. If this property and the plugin's currentFailbackPollingRate are non-zero, this value has precedence for the associate logical unit.

5.4.7 Client discovery of support for LU assignment to target port groups

If an asymmetric access device allows logical units to be assigned to target port groups, MP_TARGET_PORT_GROUP.supportsLuAssignment will be true. This indicates that MP_AssignLogicalUnitToTPG API is available.

5.5 Events

A long-running application may subscribe to events and be asynchronously notified of changes. The API has two types of events:

- visibility changes – when objects appear or disappear; and
- property changes – when properties in an object change.

APIs allow clients to register or deregister for each type of event. Registration specifies the address of a client-supplied callback method that is invoked when events occur. The client can specify a specific object type (defaults to all object types). The client can specify a specific plugin (defaults to all plugins). Multiple calls allow registration for a subset of object types and plugins.

The client can also specify “caller data” that may be used by the caller to correlate the event to source of the registration. The plugin saves the caller data and returns it with each event.

See these subclasses for more detail about events: 6.10, 6.11, 7.6, 7.7, 7.39 and 7.40.

5.6 Statistics

The API provides interfaces to report performance related statistics for a path logical unit. It defines a structure MP_PATH_LOGICAL_UNIT_STATISTICS to represent statistics typically used to measure performance of SCSI I/O operations. and also defines a structure MP_PATH_LOGICAL_UNIT_DISTRIBUTED_STATISTICS to allow multipathing support to report distributed statistics of certain performance data.

This subclass describes raw data that is collected through statistics structures and provides examples that derive performance measurement out of such data.

o Statistics Snapshot

The MP_PATH_LOGICAL_UNIT_STATISTICS structure includes

- number of I/O operations and number of processed bytes which may be subdivided into read/write and data/control categories.
- I/O response time and wait time which may be subdivided into read/write category.
- time value that represents the elapsed time since the statistics counters have been collected.
- time unit that is used across the structure.

The structure reports cumulative data that has been collected by the multipathing support that is associated with the specified path logical unit. The API clients acquire the MP_PATH_LOGICAL_UNIT_STATISTICS data by calling the MP_GetPathLogicalUnitStatistics interface. The statistics counter that is not supported by the associated multipathing support is set to MP_STATISTICS_UNSUPPORTED constant. For example, when the multipathing support that is associated with the specified path logical unit does not support control operation related statistics data, the related fields, controlOps, controlReadOps, controlWriteOps, controlBytes,

controlReadBytes and controlWriteBytes, are set to MP_STATISTICS_UNSUPPORTED constant. If the associated multipathing support collects statistics across data and control operations the ioOps, readOps, writeOps, bytes, readBytes and writeBytes fields contain the counter for both data and control operations. If the associated multipathing support collects statistics related to data operations only, it reports such data through data operation related fields, dataOps, dataReadOps, dataWriteOps, dataBytes, dataReadBytes, and dataWriteBytes. The I/O response time and wait time may be broken into read and write operations. If the associated multipathing support keeps track of response time and wait time for read and write operations separately, it will report readResponseTime, writeResponseTime, readWaitTime and writeWaitTime. Otherwise, it reports ioResponseTime and ioWaitTime.

- o Data Sampling

In order for an API client to collect sampling data between certain intervals, it may call the MP_GetPathLogicalUnitStatistics interface multiple times. The delta of statistics data between two calls can be used to derive statistics sampling. For example, two calls to MP_GetPathLogicalUnitStatistics are made and the following data has been reported through the MP_PATH_LOGICAL_UNIT_STATISTICS structure.

| | <u>1st call</u> | <u>2nd call</u> |
|----------------|-----------------|-----------------|
| snapTime | 1,000,000 | 1,100,000 |
| ioOps | 250,000 | 750,000 |
| bytes | 1,250,000,000 | 2,250,000,000 |
| ioResponseTime | 500,000 | 500,500 |
| timeUnit | MP_MILLISEC | MP_MILLISEC |

The snapTime and ioResponseTime contain time value in milliseconds. The snapTime delta, 100,000 milliseconds, and the I/O operation delta 500,000 can be used to get the sampling data, 5000 I/O operations per second over 100 second interval. The same thing can be applied to bytes statistics. The byte delta between two calls is 1,000,000,000 bytes. The byte transfer rate is 1,000,000 bytes per second and the average byte counts per I/O operation is 2,000 bytes. The response time is the time it took to actively serve an I/O request until it completes. The first call reports 500,000 milliseconds ioResponseTime and the second call reports 500,500 milliseconds IOResponseTime. The 500 milliseconds delta represents the total response time to serve 5000 I/O operations and the average ioResponseTime during that period time is 0.1 millisecond per I/O operation.

- o Distributed Statistics

The MP_PATH_LOGICAL_UNIT_DISTRIBUTED_STATISTICS structure is used to capture distributed statistics for certain types of data such as response time, wait time and byte counts on a path logical unit if the associated multipathing support provides such data. It utilizes an array of structure MP_STATISTICS_BUCKET as containers to store statistics data over multiple ranges of times or counters. The individual MP_STATISTICS_BUCKET contains number of occurrences and a boundary value which indicates an upper bound for a range relative to the previous bucket within an array of MP_STATISTICS_BUCKET. It is up to the multipathing support to determine the resolution of distributed statistics, by selection of the number of buckets and the ranges to track for each bucket. For example, the tracking bucket ranges could be selected on a linear or logarithmic basis.

In order to get distributed statistics data an API client calls MP_GetPathLogicalUnitDistributedStatistics interface which takes an OID for a path logical unit instance and statistics data type such as I/O response time, wait time or byte counts and a buffer for an array of

MP_PATH_LOGICAL_UNIT_DISTRIBUTED_STATISTICS data. The bucketCounts field of the MP_PATH_LOGICAL_UNIT_DISTRIBUTED_STATISTICS structure represents number of buckets (time or counter ranges) included in the buffer. When the client allocated buffer is not large enough to hold the data maintained by the multipathing support the API returns MP_STATUS_MORE_DATA along with actual number of buckets to be reported in the bucketCounts field to indicate that the proper buffer size to be allocated by the API client.

As an example, a client called MP_GetPathLogicalUnitDistributedStatistics on an instance of the path logical unit for MP_STATISTICS_DATA_TYPE_RESPONSE_TIME. Assuming the associated multipathing support provides distributed statistics for I/O response time, it received the following data through MP_PATH_LOGICAL_UNIT_DISTRIBUTED_STATISTICS.

```
bucketCounts: 8
snapTime: 1,000,000
timeUnit: MP_MILLISEC
```

| | <u>range</u> | <u>count</u> |
|-----------|--------------|--------------|
| bucket[0] | 1 | 0 |
| bucket[1] | 3 | 10 |
| bucket[2] | 10 | 500 |
| bucket[3] | 30 | 300 |
| bucket[4] | 100 | 50 |
| bucket[5] | 300 | 30 |
| bucket[6] | 1000 | 10 |
| bucket[7] | 32768 | 0 |

The data above is interpreted as follows. The multipathing solution tracks response time in 8 buckets of differing ranges but approximating a logarithmic distribution. The buckets are reported with increasing range values. Since the ranges of the buckets are adjacent and non-overlapping, only the upper range value of each bucket is reported in the response structure. For each range, the first (lower) range value is non-inclusive and the second (upper) range value is inclusive as shown in the illustration below. As an example the second statistics bucket holds a count of I/O operations having a response time greater than 1 and less than or equal 3. The I/O operations count is 10. The MP_MILLISEC time resolution unit applies to all reported time values.

| <u>Response time range (in milliseconds)</u> | <u>Number of I/Os</u> |
|--|-----------------------|
| > 0 and <= 1 | 0 |
| > 1 and <= 3 | 10 |
| > 3 and <= 10 | 500 |
| > 10 and <= 30 | 300 |
| > 30 and <= 100 | 50 |
| > 100 and <= 300 | 20 |
| > 300 and <= 1000 | 10 |
| > 1000 and <= 32768 | 0 |

The client made another call to the same path logical unit at a later time and received the data shown in the illustration below. The counts have been incremented by the number of I/O operations that completed after the initial call. For instance, the second statistics bucket now holds a count of 15 I/O operations that completed with a response time greater than 1 and less than or equal to 3. This means that 15 minus 10 or 5 operations completed in the elapsed time between the initial call and the later call.

It is the responsibility of the multipathing support to collect and report the counts of I/O operations that fall within in each bucket, and to determine and report all values in the statistics

structure including number of buckets and range values for each bucket. It is the responsibility of the client to interpret the contents of the returned structure including deltas in the contents between successive calls to the interface.

| <u>Response time range (in milliseconds)</u> | <u>Number of I/Os</u> |
|--|-----------------------|
| > 0 and <= 1 | 0 |
| > 1 and <= 3 | 15 |
| > 3 and <= 10 | 550 |
| > 10 and <= 30 | 330 |
| > 30 and <= 100 | 75 |
| > 100 and <= 300 | 40 |
| > 300 and <= 1000 | 20 |
| > 1000 and <= 32768 | 0 |

5.7 API concepts

5.7.1 Library and plugins

A multipath management API implementation that is compliant with this standard shall facilitate common management methodologies for configurations of multipath implementations provided by multiple vendors and installed or removed at various times. This dynamic installation and removal shall be achieved by a software structure that is either OS specific and fully documented by the OS vendor or as defined in this standard for an OS independent structure (see 5.7.2).

Functions that are shown as mandatory but are not relevant in an OS specific implementation shall return `MP_STATUS_SUCCESS` (e.g., `MP_DeregisterPlugin`) so that applications will not have to code to the specific underlying implementation.

5.7.2 OS-independent implementation

The Multipath Management API may be implemented using a combination of a library and plugins.

Among other things, the library is responsible for loading plugins and dispatching requests from a management application to the appropriate plugin(s).

In an OS-independent implementation, OS, HBA or device vendors provide plugins to manage subsets of target devices. Typically, a plugin will take a request in the generic format provided by the library and then translate that request into a vendor specific format and forward the request onto the vendor's device driver. In practice, a plugin may use a DLL or shared object library to communicate with the device driver. Also, it may communicate with multiple device drivers. Ultimately, the method a plugin uses to accomplish its work is entirely vendor specific.

Although rare, two plugins may model the same real-world resource. This could apply to initiator or target ports or even logical units. The client determines equivalence by testing the properties that contains names/lds reported by the hardware itself (such as Port WWNs for FC ports). If the client application is operating across multiple hosts, the same approach is used to look for occurrences of the same target port of logical unit connected to multiple hosts. This allows a client to have a single instance that aggregates information from several plugins. One consequence of this overlap is that multiple plugins may report the same event to the client.

This architecture has no boot-time requirements. Plugins are registered with the common library when they are installed. This would typically be done when MP drivers (and/or management clients) are installed on the system. The registration information is persistent and resides in either a registry or in a configuration file (see 7.41).

5.7.3 Object ID

The core element of the Multipath Management API is the object ID (OID). An object ID is a structure that “uniquely” identifies an object. The reason uniquely is in quotes in the previous sentence is that it is possible, though very unlikely, that an object ID would be reused and refer to a different object.

An object ID consists of three fields:

- a) An object type. This identifies the type of object, e.g. port, logical unit, etc., that the object ID refers to;
- b) An object owner identifier. This is a number that is used to uniquely identify the owner of the object. Either the library or a plugin owns objects; and
- c) An object sequence number. This is a number used by the owner of an object, possibly in combination with the object type, to identify an object.

The combination of these properties assures that object IDs are unique across plugins.

To a client that uses the library, object IDs shall be considered opaque. A client shall use only documented APIs to access information found in the object ID.

There are several rules for object IDs that the library, plugins and clients shall follow. They are:

an object ID can only refer to one object at a time;

an object can only have one object ID that refers to it at any one time. It is not permissible to have two or more object IDs that refer to the same object at the same time. In some cases this may be difficult, but the rule still shall be followed.

For example, suppose a HBA port is in a system. That HBA port will have an object ID. If the HBA is removed and then reinserted (while the associated plugin is running) then one of two things can happen;

- a) the HBA port can retain the same object ID as it had before it was removed; or
- b) The HBA port can get a new object ID and the old object ID will no longer be usable.

This can only happen if the same HBA is reinserted. If a HBA is removed and another HBA is inserted that has not been in the system while a particular instance of the library and plugins are running then that HBA port shall be given a new object ID.

The library and plugins can uniquely identify an object within their own object space by using either the object sequence number or by using the object sequence number in combination with the object type. Which method is used is up to the implementer of the library or plugin.

Object sequence numbers shall be reused in a conservative fashion to minimize the possibility that (due to wrapping of the sequence number) an object ID will ever refer to two (or more) different objects in any one instance of the library or plugin. This rule for reuse only applies to a particular instance of the library or plugin. Neither the library nor plugins are required or expected to persist object sequence numbers across instances.

Because neither the library nor plugins are required to persist object sequence numbers a client using the library shall not use persisted object IDs across instances of itself.

Similarly, different instances of the library and plugins may use different object IDs to represent the same physical entity.

5.7.4 Object ID list

An object ID list is a list of zero or more object IDs. There are several APIs, e.g., [MP_GetTargetPortOidList](#), that return object ID lists. Once a client is finished using an object ID list the client shall free the memory used by the list by calling the [MP_FreeOidList](#) API.

6 Constants and structures

6.1 MP_WCHAR

Typedef'd as a wchar_t (wchar_t is part of the ISO C programming standard ISO/IEC 9899:1999) and is available in all recent C compilers, though you may need special options to enable it).

6.2 MP_CHAR

Typedef'd as a char. Only used in contexts where wide characters cannot be used, such as filenames and ASCII text returned from SCSI commands.

6.3 MP_BYTE

An 8-bit unsigned value. Typedef'd as an unsigned char.

6.4 MP_BOOL

Typedef'd to an MP_UINT32. A variable of this type can have either of the following values:

- MP_TRUE
This symbol has the value 1.
- MP_FALSE
This symbol has the value 0.

6.5 MP_XBOOL

Typedef'd to an MP_UINT32. This is an extended boolean. A variable of this type can have any of the following values:

- MP_TRUE
This symbol has the value 1.
- MP_FALSE
This symbol has the value 0.
- MP_UNKNOWN
This symbol has the value FFFFFFFFh.

6.6 MP_UINT32

A 32-bit unsigned integer value.

6.7 MP_UINT64

A 64-bit unsigned integer value.

6.8 MP_STATUS

Status values

MP_STATUS_SUCCESS

This status value is returned when the requested operation is successfully carried out. This symbol has a value of 0.

MP_STATUS_INVALID_PARAMETER

This status value is returned when parameter(s) passed to an API is detected to be invalid or inappropriate for a particular API parameter. If the parameter is an object ID, this

status indicates that the object type subfield is defined in this standard, but is not appropriate for this API. This symbol has a value of 1.

MP_STATUS_UNKNOWN_FN

This status value is returned when a client function passed into the API is not a previously registered/known function. This symbol has a value of 2.

MP_STATUS_FAILED

This status value is returned when the requested operation could not be carried out. This symbol has a value of 3.

MP_STATUS_INSUFFICIENT_MEMORY

This status value is returned when the API could not allocate the memory required to complete the requested operation. This symbol has a value of 4.

MP_STATUS_INVALID_OBJECT_TYPE

This status value is returned when an object id includes a type subfield that is not defined in this standard. This symbol has a value of 5.

MP_STATUS_OBJECT_NOT_FOUND

This status value is returned when the object associated with the id specified in the API could not be located or has been deleted. Note that an invalid object type is covered by MP_STATUS_INVALID_OBJECT_TYPE so this status is limited to invalid object owner identifier or sequence number. This symbol has a value of 6.

MP_STATUS_UNSUPPORTED

This status value is returned when the implementation does not support the requested function. This symbol has a value of 7.

MP_STATUS_FN_REPLACED

This status value is returned when a client function passed into the API replaces a previously registered function. This symbol has a value of 8.

MP_STATUS_ACCESS_STATE_INVALID

This status value is returned when a device processing MP_SetTPGAccess returns a status indicating the caller is attempting to establish an illegal combination of access states. This symbol has a value of 9.

MP_STATUS_PATH_NONOPERATIONAL

This status is returned when communication cannot be established with the path selected by the caller. This symbol has a value of 10.

MP_STATUS_TRY_AGAIN

This status is returned when the plugin/driver is unable to complete the request at this time, but may be able to complete it later. This symbol has a value of 11.

MP_STATUS_NOT_PERMITTED

The operation is not permitted in the current configuration, but may be permitted in other configurations. This symbol has a value of 12.

MP_STATUS_LU_NONOPERATIONAL

This status is returned when the multipath logical unit is not operational so the requested operation may not be completed. The symbol has a value of 13.

MP_STATUS_REBOOT_NECESSARY

This status is returned when host reboot is required for the requested operations to be effective. For example, the addition of the device product requires a re-boot of the host for a plugin to configure the associated device as a multipath device. The symbol has a value of 14.

MP_STATUS_MORE_DATA

This status is returned when the client provided data buffer is not enough to store the requested information. The symbol has a value of 15.

6.9 MP_PATH_STATE

MP_PATH_STATE is an enumeration used to indicate the status of a path. This status is not returned by APIs, but is included in MP_PATH_LOGICAL_UNIT_PROPERTIES along with other path properties.

Constants

```
#define MP_PATH_STATE_OKAY 0
#define MP_PATH_STATE_PATH_ERR 1
#define MP_PATH_STATE_LU_ERR 2
#define MP_PATH_STATE_RESERVED 3
#define MP_PATH_STATE_REMOVED 4
#define MP_PATH_STATE_TRANSITIONING 5
#define MP_PATH_STATE_OPERATIONAL_CLOSED 6
#define MP_PATH_STATE_INVALID_CLOSED 7
#define MP_PATH_STATE_OFFLINE_CLOSED 8
#define MP_PATH_STATE_UNKNOWN 9

typedef MP_UINT32 MP_PATH_STATE;
```

Definitions

MP_PATH_STATE_OKAY
The path is okay.

MP_PATH_STATE_PATH_ERR
The path is unusable due to an error on this path and no SCSI status was received.

MP_PATH_STATE_LU_ERR
A SCSI status was received for an I/O through this path indicating an error on the logical unit.

MP_PATH_STATE_RESERVED
The path is unusable due to a SCSI reservation.

MP_PATH_STATE_REMOVED
The path is not used because the OS or other drivers marked the path unusable.

MP_PATH_TRANSITIONING
The path is transitioning between two valid states.

MP_PATH_STATE_OPERATIONAL_CLOSED
The path appears operational, but has not been opened. This state only applies to platforms that allow paths to be opened or closed.

MP_PATH_STATE_INVALID_CLOSED
No open was attempted but background probing determined that the path was dead.

MP_PATH_STATE_OFFLINE_CLOSED
The path appears operational, but has not been opened.

MP_PATH_STATE_UNKNOWN
The path is not operational, but the exact cause is not known.

Remarks

The error states are generally discovered when an I/O requests do not complete with normal status. The I/O request involved in this state change may have been issued by the multipath plugin/driver or by a user application. This standard does not require that the plugin/driver poll for error conditions. If these error states are known, they may be returned; if details are not known, MP_PATH_STATE_UNKNOWN should be returned.

6.10 MP_OBJECT_VISIBILITY_FN

Format

```
typedef void (* MP_OBJECT_VISIBILITY_FN)(
    /* in */ MP_BOOL    becomingVisible,
    /* in */ MP_OID_LIST *pOidList,
    /* in */ void      *pCallerData
);
```

Parameters

becomingVisible

Multipath Management API

SNIA Technical Position
Version 1.1

An MP_BOOL value indicating that the list of object specified by *pOidList* have become visible or have disappeared. A value of MP_TRUE indicates the objects have become visible. A value of MP_FALSE indicates the objects have disappeared.

pOidList

A list of IDs of objects whose visibility is being changed. All objects referenced shall be of the same type (different types may have different pCallerData values). All objects referenced shall all have become visible or have disappeared.

pCallerData

The pCallerData passed into MP_RegisterForObjectVisibilityChanges. This may be used by the caller to correlate the event to source of the registration.

Remarks

This type is used to declare client functions that can be used with the MP_RegisterForObjectVisibilityChanges and MP_DeregisterForObjectVisibilityChanges APIs.

When the client function is finished using the list referenced by pOidList, it shall free the memory used by the list by calling MP_FreeOidList.

6.11 MP_OBJECT_PROPERTY_FN

Format

```
typedef void (* MP_OBJECT_PROPERTY_FN)(
    /* in */ MP_OID_LIST *pOidList,
    /* in */ void *pCallerData
);
```

Parameters

pOidList

A list of IDs of objects whose property values are being changed. All objects referenced shall be of the same type (different types may have different pCallerData values)

pCallerData

The pCallerData passed into MP_RegisterForObjectPropertyChanges. This may be used by the caller to correlate the event to source of the registration.

Remarks

This type is used to declare client functions that can be used with the MP_RegisterForObjectPropertyChanges and MP_DeregisterForObjectPropertyChanges APIs.

When the client function is finished using the list referenced by pOidList, it shall free the memory used by the list by calling MP_FreeOidList.

6.12 MP_OBJECT_TYPE

MP_OBJECT_TYPE is an enumeration used to differentiate API objects that are referenced by object Ids (odes). MP_OBJECT_TYPE is not directly used by clients, but is used to form object Ids.

Constants

```
#define MP_OBJECT_TYPE_UNKNOWN          0
#define MP_OBJECT_TYPE_PLUGIN           1
#define MP_OBJECT_TYPE_INITIATOR_PORT   2
#define MP_OBJECT_TYPE_TARGET_PORT      3
#define MP_OBJECT_TYPE_MULTIPATH_LU     4
#define MP_OBJECT_TYPE_PATH_LU          5
#define MP_OBJECT_TYPE_DEVICE_PRODUCT   6
#define MP_OBJECT_TYPE_TARGET_PORT_GROUP 7
```

```
#define MP_OBJECT_TYPE_PROPRIETARY_LOAD_BALANCE 8
```

```
typedef MP_UINT32 MP_OBJECT_TYPE;
```

Definitions

MP_OBJECT_TYPE_UNKNOWN

The object has an unknown type. If an object has this type its most likely an uninitialized object.

MP_OBJECT_TYPE_PLUGIN

Object type to identify a plugin module.

MP_OBJECT_TYPE_INITIATOR_PORT

Object type to identify an initiator port.

MP_OBJECT_TYPE_TARGET_PORT

Object type to identify an initiator port.

MP_OBJECT_TYPE_MULTIPATH_LU

Object type to identify the multipath logical unit.

MP_OBJECT_TYPE_PATH_LU

Object type to identify the path logical unit.

MP_OBJECT_TYPE_DEVICE_PRODUCT

Object type to identify the device product.

MP_OBJECT_TYPE_TARGET_PORT_GROUP

Object type to identify the target port group.

MP_OBJECT_TYPE_PROPRIETARY_LOAD_BALANCE

Object type to identify a proprietary load balance type.

6.13 MP_OID

Format

```
typedef struct _MP_OID
{
    MP_OBJECT_TYPE    objectType;
    MP_UINT32         ownerId;
    MP_UINT64         objectSequenceNumber;
} MP_OID;
```

Fields

objectType

Specifies the type of object. When an object ID is supplied as a parameter to an API the library uses this value to ensure that the supplied object's type is appropriate for the API that was called.

ownerId

A number determined by the library that it uses to uniquely identify the owner of an object. The owner of an object is either the library itself or a plugin. When an object ID is supplied as a parameter to an API the library uses this value to determine if it should handle the call itself or direct the call to one or more plugins.

objectSequenceNumber

A number determined by the owner of an object, that is used by the owner possibly in combination with the object type, to uniquely identify an object.

Remarks

Clients of the API shall treat this structure as opaque. Appropriate APIs, e.g., `MP_GetObjectType` and `MP_GetAssociatedPluginOid`, shall be used to extract information from the structure.

6.14 MP_OID_LIST

Format

```
typedef struct _MP_OID_LIST
{
    MP_UINT32      oidCount;
    MP_OID         oids[1];
} MP_OID_LIST;
```

Fields

oidCount

The number of object IDs in the *oids* array.

oids

A variable length array of zero or more object IDs. There are *oidCount* objects IDs in this array.

Remarks

This structure is used by a number of APIs to return lists of objects. Any instance of this structure returned by an API shall be freed by a client using the `MP_FreeOidList` API.

Although *oids* is declared to be an array of one `MP_OID` structure it can in fact contain any number of `MP_OID` structures.

6.15 MP_PORT_TRANSPORT_TYPE

Constants

```
#define MP_PORT_TRANSPORT_TYPE_UNKNOWN 0
#define MP_PORT_TRANSPORT_TYPE_MPNODE 1
#define MP_PORT_TRANSPORT_TYPE_FC      2
#define MP_PORT_TRANSPORT_TYPE_SPI     3
#define MP_PORT_TRANSPORT_TYPE_ISCSI   4
#define MP_PORT_TRANSPORT_TYPE_IFB     5
#define MP_PORT_TRANSPORT_TYPE_SAS     6
#define MP_PORT_TRANSPORT_TYPE_FCOE    7
```

```
typedef MP_UINT32 MP_PORT_TRANSPORT_TYPE;
```

Definitions

`MP_PORT_TRANSPORT_TYPE_UNKNOWN`

The associated port is of an unknown transport type.

`MP_PORT_TRANSPORT_TYPE_MPNODE`

For initiator ports only, the associated port is known to be a virtual construct of an underlying multipath driver.

`MP_PORT_TRANSPORT_TYPE_FC`

The associated port represents a Fibre Channel port. The Name for the port should be a port WWN formatted as 16 unseparated hexadecimal digits, with no leading 0x.

`MP_PORT_TRANSPORT_TYPE_SPI`

The associated port represents a parallel SCSI port.

`MP_PORT_TRANSPORT_TYPE_ISCSI`

The associated port represents an iSCSI initiator or target port. The port name should be an iSCSI name in “iqn”, “eui”, or “naa” format and include “,i,0x” followed by an ISID (for initiator ports) or “,t,0x” followed by a TGPIID (for target ports).

`MP_PORT_TRANSPORT_TYPE_IFB`

The associated port represents a mapped Fibre Channel port on an InfiniBand initiator. The name should be formatted as a FC PortWWN.

MP_PORT_TRANSPORT_TYPE_SAS

The associated port represents a Serial Attached SCSI port. The port name should be the SAS address that is assigned to the port. The SAS standard allows different SAS ports to have the same SAS address assigned if they are connected to different SAS domains. When multiple ports are assigned with the same SAS address additional information such as an SAS phy identifier as defined in SAS standard may be included to the name. The port name should be world wide unique.

MP_PORT_TRANSPORT_TYPE_FCOE

The associated port represents a Fibre Channel over Ethernet port. The port name should be formatted as a FC portWWN.

Remarks

This type serves two purposes. It identifies the type of transport and the format of the PORT_ID property.

6.16 MP_ACCESS_STATE_TYPE

Constants

```
#define MP_ACCESS_STATE_ACTIVE_OPTIMIZED      0h
#define MP_ACCESS_STATE_ACTIVE_NONOPTIMIZED  1h
#define MP_ACCESS_STATE_STANDBY              2h
#define MP_ACCESS_STATE_UNAVAILABLE          3h
#define MP_ACCESS_STATE_TRANSITIONING        Fh
#define MP_ACCESS_STATE_ACTIVE               10h
```

```
typedef MP_UINT32 MP_ACCESS_STATE_TYPE;
```

Definitions

MP_ACCESS_STATE_ACTIVE_OPTIMIZED

“All target ports within a target port group should be capable of immediately accessing the logical unit.”

MP_ACCESS_STATE_ACTIVE_NONOPTIMIZED

“The processing of some ... commands may operate with lower performance than they would if the target port were in the active/optimized target port ...access state.”

MP_ACCESS_STATE_STANDBY

The logical unit only supports a small set of management commands and no data transfer commands.

MP_ACCESS_STATE_UNAVAILABLE

“The unavailable target port ... access state is intended for situations when the target port accessibility to a logical unit may be severely restricted due to SCSI target device limitations (e.g., hardware errors).”

MP_ACCESS_STATE_TRANSITIONING

Indicates the target device is in the process of transitioning between access states. This value cannot be specified by a client, but can be exposed to clients as a property of a target port group.

MP_ACCESS_STATE_ACTIVE

Used when the client is requesting that target port groups be activated (using the MP_SetTPGAccess API) but does not care whether these port groups are given an active optimized or active non-optimized state. This value will not be returned in a property. This value is not defined in ISO/IEC 14776-453 (SPC-3).

NOTE The descriptions above, indicated in quotation marks, are quoted or paraphrased from ISO/IEC 14776-453 (SPC-3).

Remarks

This enumerated type provides the target port (group) states as described in ISO/IEC 14776-453 (SPC-3).

6.17 MP_LOAD_BALANCE_TYPE

Constants

```
#define MP_LOAD_BALANCE_TYPE_UNKNOWN          1<<0,
#define MP_LOAD_BALANCE_TYPE_ROUNDROBIN     1<<1,
#define MP_LOAD_BALANCE_TYPE_LEASTBLOCKS    1<<2,
#define MP_LOAD_BALANCE_TYPE_LEASTIO       1<<3,
#define MP_LOAD_BALANCE_TYPE_DEVICE_PRODUCT 1<<4,
#define MP_LOAD_BALANCE_TYPE_LBA_REGION     1<<5,
#define MP_LOAD_BALANCE_TYPE_FAILOVER_ONLY 1<<6,
#define MP_LOAD_BALANCE_TYPE_PROPRIETARY1   1<<16,
#define MP_LOAD_BALANCE_TYPE_PROPRIETARY2   1<<17
// additional proprietary types

typedef MP_UINT32 MP_LOAD_BALANCE_TYPE;
```

Definitions

MP_LOAD_BALANCE_TYPE_UNKNOWN

The load balance object has an unknown type. If the load balance field has this type then, it is most likely an uninitialized object.

MP_LOAD_BALANCE_TYPE_ROUNDROBIN

Load balancing object type that is associated with the algorithm that performs load balancing in a round robin manner.

MP_LOAD_BALANCE_TYPE_LEASTBLOCKS

Load balancing object type that is associated with the algorithm that performs load balancing using the least blocks as a criteria to select a path for forwarding the request.

MP_LOAD_BALANCE_TYPE_LEASTIO

Load balancing object type that is associated with the algorithm that performs load balancing using the least used I/O path as a criteria for forwarding the request.

MP_LOAD_BALANCE_TYPE_DEVICE_PRODUCT

The load balance algorithm is optimized for the device specified in the MP_DEVICE_PRODUCT_PROPERTIES class associated with the logical unit.

MP_LOAD_BALANCE_TYPE_LBA_REGION

Load balancing object type that is associated with the algorithm that performs load balancing using the sequential stream detection algorithm.

MP_LOAD_BALANCE_TYPE_FAILOVER_ONLY

Set in MP_DEVICE_PRODUCT_PROPERTIES when the plugin/driver has determined that the device supports SCSI 2 RESERVE/RELEASE. Used by API clients to indicate that SCSI 2 reservations are in use and multipathing is only to be used for failover.

MP_LOAD_BALANCE_TYPE_PROPRIETARYx

The load balance algorithm is proprietary. This bit mask supports up to sixteen proprietary types.

Remarks

Plugin support for device-type specific load balance types is expressed through instances of MP_DEVICE_PRODUCT_PROPERTIES. If this property is MP_LOAD_BALANCE_TYPE_DEVICE_PRODUCT then the vendor, product and revision properties of the logical unit shall match those of instances of MP_DEVICE_PRODUCT_PROPERTIES. In contexts where MP_LOAD_BALANCE_TYPE refers to the current or default value, a single flag should be set or the value should be zero if no load balancing algorithm is in use.

See MP_PROPRIETARY_LOAD_BALANCE_PROPERTIES.

6.18 MP_PROPRIETARY_PROPERTY

Format

```
typedef struct _MP_PROPRIETARY_PROPERTY
{
    MP_WCHAR        name[16];
    MP_WCHAR        value[48];
} MP_PROPRIETARY_PROPERTIES;
```

Fields

name

A null terminated Unicode string containing the name of the proprietary property.

value

A null terminated Unicode string containing the value associated with the proprietary property.

Remarks

A name and value for a proprietary property. Arrays of proprietary properties are included in some data structures.

6.19 MP_PROPRIETARY_LOAD_BALANCE_PROPERTIES

Format

```
typedef struct _MP_PROPRIETARY_LOAD_BALANCE_PROPERTIES
{
    MP_LOAD_BALANCE_TYPE    typeIndex;
    MP_WCHAR                name[256];
    MP_WCHAR                vendorName[256];
    MP_UINT32               proprietaryPropertyCount;
    MP_PROPRIETARY_PROPERTY proprietaryProperties[8];
} MP_PROPRIETARY_LOAD_BALANCE_PROPERTIES;
```

Fields

typeIndex

The value (65536 or greater) representing a vendor-specific load balance algorithm.

name

A name for the vendor-specific load-balancing algorithm. This name is only meaningful to a vendor-specific client application.

vendorName

A name for the vendor associated with the load-balancing algorithm.

proprietaryPropertyCount

The count of proprietary properties (less than or equal to eight) supported.

proprietaryProperties

A list of proprietary property name/value pairs.

Remarks

This structure is optional and allows a vendor to add up to 16 vendor-specific load-balance algorithms to the load balance bit maps used in logical unit and plugin properties.

See MP_LOAD_BALANCE_TYPE

6.20 MP_LOGICAL_UNIT_NAME_TYPE

Constants

```
#define MP_LU_NAME_TYPE_UNKNOWN    0
#define MP_LU_NAME_TYPE_VPD83_TYPE1 1
```

```

#define MP_LU_NAME_TYPE_VPD83_TYPE2      2
#define MP_LU_NAME_TYPE_VPD83_TYPE3      3
#define MP_LU_NAME_TYPE_DEVICE_SPECIFIC  4

typedef MP_UINT32 MP_LOGICAL_UNIT_NAME_TYPE;

```

Definitions

MP_LOGICAL_UNIT_NAME_TYPE_UNKOWN

The interpretation of the name for the logical unit is unknown. Use of this value is discouraged and should only be used if the name is derived from some other driver rather than directly from a SCSI Inquiry command.

MP_LU_NAME_TYPE_VPD83_TYPE1

The name is derived from SCSI Device Identification VPD page (i.e., page 83h), Association 0, Type 1.

MP_LU_NAME_TYPE_VPD83_TYPE2

The name is derived from SCSI Device Identification VPD page (i.e., page 83h), Association 0, Type 2.

MP_LU_NAME_TYPE_VPD83_TYPE3

The name is derived from SCSI Device Identification VPD page (i.e., page 83h), Association 0, Type 3.

MP_LU_NAME_TYPE_DEVICE_SPECIFIC

The name is derived from a device product specific command.

Remarks

ISO/IEC 14776-453 (SPC-3) allows for several different representations of logical unit names. This property is an enumerated type for commonly used formats.

6.21 MP_LIBRARY_PROPERTIES

Format

```

typedef struct _MP_LIBRARY_PROPERTIES
{
    MP_UINT32      supportedMpVersion;
    MP_WCHAR      vendor[256];
    MP_WCHAR      implementationVersion[256];
    MP_CHAR       fileName[256];
    MP_WCHAR      buildTime[256];
} MP_LIBRARY_PROPERTIES;

```

Fields

supportedMpVersion

The version of the Multipath Management API implemented by the library. The value returned by a library for the API as described in this document is one.

vendor

A null terminated Unicode string containing the name of the vendor that created the binary version of the library.

implementationVersion

A null terminated Unicode string containing the implementation version of the library from the vendor specified in *vendor*.

fileName

A null terminated ASCII string ideally containing the path and file name of the library that is filling in this structure.

If the path cannot be determined then this field will contain only the name (and extension if applicable) of the file of the library. If this cannot be determined then this field shall be an empty string.

buildTime

The time and date that the library was built.

6.22 MP_AUTOFAILBACK_SUPPORT

Constants

```
#define MP_AUTOFAILBACK_SUPPORT_NONE          0
#define MP_AUTOFAILBACK_SUPPORT_PLUGIN       1
#define MP_AUTOFAILBACK_SUPPORT_MPLU        2
#define MP_AUTOFAILBACK_SUPPORT_PLUGINANDMPLU 3
```

```
typedef MP_UINT32 MP_AUTOFAILBACK_SUPPORT;
```

Definitions

MP_AUTOFAILBACK_SUPPORT_NONE

The implementation does not support auto-failback.

MP_AUTOFAILBACK_SUPPORT_PLUGIN

The implementation supports auto-failback properties and APIs across the entire plugin.

MP_AUTOFAILBACK_SUPPORT_MPLU

The implementation supports auto-failback properties and APIs for individual multipath logical units.

MP_AUTOFAILBACK_SUPPORT_PLUGINANDMPLU

The implementation supports auto-failback properties and APIs for plugins and individual multipath logical units.

Remarks

Auto-failback is the capability of the implementation to discover that a path has reverted to a usable state and to resume using the path. If the implementation supports auto-failback, then it supports the MP_SetFailbackPollingRate API or shall assure MP_PLUGIN_PROPERTIES failbackPollingRateMax is set to 0 (indicating polling is not performed or the rate is not tunable).

6.23 MP_AUTOPROBING_SUPPORT

Constants

```
#define MP_AUTOPROBING_SUPPORT_NONE          0
#define MP_AUTOPROBING_SUPPORT_PLUGIN       1
#define MP_AUTOPROBING_SUPPORT_MPLU        2
#define MP_AUTOPROBING_SUPPORT_PLUGINANDMPLU 3
```

```
typedef MP_UINT32 MP_AUTOPROBING_SUPPORT;
```

Definitions

MP_AUTOPROBING_SUPPORT_NONE

The implementation does not support auto-probing.

MP_AUTOPROBING_SUPPORT_PLUGIN

The implementation supports auto-probing properties and APIs across the entire plugin.

MP_AUTOPROBING_SUPPORT_MPLU

The implementation supports auto-probing properties and APIs for individual multipath logical units.

MP_AUTOPROBING_SUPPORT_PLUGINANDMPLU

The implementation supports auto-probing properties and APIs for plugins and individual multipath logical units.

Remarks

Auto-probing is the capability of the implementation to discover state changes in paths that are not being used. Paths may not be used because of administrative weight or path override configurations. If the implementation supports auto-probing, then it supports the `MP_SetProbingPollingRate` API or shall assure `MP_PLUGIN_PROPERTIES` `probingPollingRateMax` is set to 0 (indicating polling is not performed or the rate is not tunable).

6.24 MP_PLUGIN_PROPERTIES

Format

```
typedef struct _MP_PLUGIN_PROPERTIES
{
    MP_UINT32          supportedMpVersion;
    MP_WCHAR           vendor[256];
    MP_WCHAR           implementationVersion[256];
    MP_CHAR            fileName[256];
    MP_WCHAR           buildTime[256];
    MP_WCHAR           driverVendor[256];
    MP_CHAR            driverName[256];
    MP_WCHAR           driverVersion[256];
    MP_UINT32          supportedLoadBalanceTypes;
    MP_BOOL            canSetTPGAccess;
    MP_BOOL            canOverridePaths;
    MP_BOOL            exposesPathDeviceFiles;
    MP_CHAR            deviceFileNamespace[256];
    MP_BOOL            onlySupportsSpecifiedProducts;
    MP_UINT32          maximumWeight;
    MP_AUTOFAILBACK_SUPPORT autoFailbackSupport;
    MP_BOOL            pluginAutoFailbackEnabled;
    MP_UINT32          failbackPollingRateMax;
    MP_UINT32          currentFailbackPollingRate;
    MP_AUTOPROBING_SUPPORT autoProbingSupport;
    MP_BOOL            pluginAutoProbingEnabled;
    MP_UINT32          probingPollingRateMax;
    MP_UINT32          currentProbingPollingRate;
    MP_LOAD_BALANCE_TYPE defaultloadBalanceType;
    MP_UINT32          proprietaryPropertyCount;
    MP_PROPRIETARY_PROPERTY proprietaryProperties[8];
} MP_PLUGIN_PROPERTIES;
```

Fields

`supportedMpVersion`

The version of the Multipath Management API implemented by a plugin. The value returned by a library for the API as described in this document is one.

`vendor`

A null terminated Unicode string containing the name of the vendor that created the binary version of the plugin.

`implementationVersion`

A null terminated Unicode string containing the implementation version of the plugin from the vendor specified in `vendor`.

`fileName`

A null terminated ASCII string ideally containing the path and file name of the plugin that is filling in this structure.

If the path cannot be determined then this field will contain only the name (and extension if applicable) of the file of the plugin. If this cannot be determined then this field will be an empty string.

buildTime

The time and date that the plugin that is specified by this structure was built.

driverVendor

A null terminated Unicode string containing the name of the multipath driver vendor associated with this plugin.

driverName

A null terminated ASCII string containing the name of the multipath driver associated with the plugin.

driverVersion

A null terminated Unicode string containing the version number of the multipath driver.

supportedLoadBalanceTypes

A set of flags representing the load balance types (MP_LOAD_BALANCE_TYPES) supported by the plugin/driver as a plugin-wide property.

canSetTPGAccess

A boolean indicating whether the implementation supports activating target port groups.

canOverridePaths

A boolean indicating whether the implementations supports overriding paths. Setting this to true indicates MP_SetOverridePath and MP_CancelOverridePath are supported.

exposesPathDeviceFiles

A boolean indicating whether the implementation exposes (or leaves exposed) device files for the individual paths encapsulated by the multipath device file. This is typically true for MP drivers that sit near the top of the driver stack.

deviceFileNamespace

A string representing the primary file names the driver uses for multipath logical units, if those filenames do not match the names in A.1. The name is expressing in the following format:

'*' represents one or more alphanumeric characters

'#' represents a string of consecutive digits (e.g. '5', '123')

'%' represents a string of hexadecimal digits (e.g. '6101a45')

'\' is an escape character for literal presentation of *, #, or % (e.g. 'lu#5')

any other character is interpreted literally

For example, "/dev/vx/dmp/*"

If the multipath driver creates multipath logical unit device file names in the same manner as OS device files, then this property should be left null.

onlySupportsSpecifiedProducts

A boolean indicating whether the driver limits multipath capabilities to certain device types. If true, then the driver only provides multipath support to devices exposed through MP_DEVICE_PRODUCT_PROPERTIES instances. If false, then the driver supports any device that provides standard SCSI logical unit identifiers.

maximumWeight

Describes the range of administer settable path weights supported by the driver. A driver with no path preference capabilities should set this property to zero. A driver with the ability to enable/disable paths should set this property to 1. Drivers with more weight settings can set the property appropriately.

autoFailbackSupport

An enumerated type indicating whether the implementation supports auto-failback at the plugin level, the multipath logical unit level, both levels or whether auto-failback is unsupported.

pluginAutoFailbackEnabled

A boolean indicating that plugin-wide auto-failback is enabled. This property is undefined if autoFailbackSupport is MP_AUTOFAILBACK_SUPPORT_NONE or MP_AUTOFAILBACK_SUPPORT_MPLU.

failbackPollingRateMax

The maximum plugin-wide polling rate (in seconds) for auto-failback supported by the driver. Undefined if autofailbackSupport is MP_AUTOFAILBACK_SUPPORT_NONE or MP_AUTOFAILBACK_SUPPORT_MPLU. If the plugin/driver supports auto-failback without polling or does not provide a way to set the polling rate, then this shall be set to zero (0). This value is set by the plugin and cannot be modified by users.

currentFailbackPollingRate

The current plugin-wide auto-failback polling rate (in seconds). Undefined if autofailbackSupport is MP_AUTOFAILBACK_SUPPORT_NONE or MP_AUTOFAILBACK_SUPPORT_MPLU. Cannot be more than failbackPollingRateMax.

autoProbingSupport

An enumerated type indicating whether the implementation supports auto-probing at the plugin level, the multipath logical unit level, both levels or whether auto-probing is unsupported.

pluginAutoProbingEnabled

A boolean indicating that plugin-wide auto-probing is enabled. This property is undefined if autoProbingSupport is MP_AUTOPROBING_SUPPORT_NONE or MP_AUTOPROBING_SUPPORT_MPLU.

probingPollingRateMax

The maximum plugin-wide polling rate (in seconds) for auto-probing supported by the driver. Undefined if autoProbingSupport is MP_AUTOPROBING_SUPPORT_NONE or MP_AUTOPROBING_SUPPORT_MPLU. If the plugin/driver supports auto-probing without polling or does not provide a way to set the probing polling rate, then this shall be set to zero (0). This value is set by the plugin and cannot be modified by users.

currentProbingPollingRate

The current plugin-wide auto-probing polling rate (in seconds). Undefined if autoProbingSupport is MP_AUTOPROBING_SUPPORT_NONE or MP_AUTOPROBING_SUPPORT_MPLU. Cannot be more than probingPollingRateMax.

defaultLoadBalanceType

The load balance type that will be used by the driver for devices (without a corresponding MP_DEVICE_PRODUCT_PROPERTIES instance) unless overridden by the administrator. Any logical unit with vendor, product and revision properties matching a MP_DEVICE_PRODUCT_PROPERTIES instance will default to a device-specific load balance type.

proprietaryPropertyCount

The count of proprietary properties (less than or equal to eight) supported.

proprietaryProperties

A list of proprietary property name/value pairs.

6.25 MP_SUPPORTED_DEVICE_PRODUCT_CATEGORY

Constants

```
#define MP_DEVICE_PRODUCT_SPECIFIC_ONLY 0
#define MP_DEVICE_PRODUCT_SPECIFIC_SYMMETRIC_EXPLICIT 1 << 0
#define MP_DEVICE_PRODUCT_SPECIFIC_SYMMETRIC_IMPLICIT 1 << 1
#define MP_DEVICE_PRODUCT_SPECIFIC_ASYMMETRIC_EXPLICIT 1 << 2
#define MP_DEVICE_PRODUCT_SPECIFIC_ASYMMETRIC_IMPLICIT 1 << 3
#define MP_DEVICE_PRODUCT_SCSI_TPGS_SYMMETRIC_EXPLICIT 1 << 4
#define MP_DEVICE_PRODUCT_SCSI_TPGS_SYMMETRIC_IMPLICIT 1 << 5
#define MP_DEVICE_PRODUCT_SCSI_TPGS_ASYMMETRIC_EXPLICIT 1 << 6
#define MP_DEVICE_PRODUCT_SCSI_TPGS_ASYMMETRIC_IMPLICIT 1 << 7
```

```
typedef MP_UINT32 MP_SUPPORTED_DEVICE_PRODUCT_CATEGORY
```

Definitions

MP_DEVICE_PRODUCT_SPECIFIC_ONLY

The plugin supports a specific device product.

MP_DEVICE_PRODUCT_SPECIFIC_SYMMETRIC_EXPLICIT

The plugin supports specific symmetric device with explicit state change support.

MP_DEVICE_PRODUCT_SPECIFIC_SYMMETRIC_IMPLICIT

The plugin supports specific symmetric device with implicit state change support.

MP_DEVICE_PRODUCT_SPECIFIC_ASYMMETRIC_EXPLICIT

The plugin supports specific asymmetric device with explicit state change support.

MP_DEVICE_PRODUCT_SPECIFIC_ASYMMETRIC_IMPLICIT

The plugin supports specific asymmetric device with implicit state change support.

MP_DEVICE_PRODUCT_SCSI_TPGS_SYMMETRIC_EXPLICIT

The plugin supports T10 TPGS compliant symmetric device with explicit state change support.

MP_DEVICE_PRODUCT_SCSI_TPGS_SYMMETRIC_IMPLICIT

The plugin support T10 TPGS compliant symmetric device with implicit state change support.

MP_DEVICE_PRODUCT_SCSI_TPGS_ASYMMETRIC_EXPLICIT

The plugin supports T10 TPGS compliant asymmetric device with explicit state change support.

MP_DEVICE_PRODUCT_SCSI_TPGS_ASYMMETRIC_IMPLICIT

The plugin support T10 TPGS compliant asymmetric device with implicit state change support.

Remarks

The categories defined in this section serve to complement the information of `MP_DEVICE_PRODUCT_PROPERTIES` instances when the `onlySupportsSpecifiedProducts` field is set to true. A multipath support may provide a vendor specific way to manage supported device product when `MP_DEVICE_PRODUCT_SPECIFIC_*` categories are supported.

See Also

`MP_GetSupportedDeviceProductCategory`

6.26 MP_DEVICE_PRODUCT_PROPERTIES

Format

```
typedef struct _MP_DEVICE_PRODUCT_PROPERTIES
{
    MP_CHAR          vendor[8];
    MP_CHAR          product[16];
    MP_CHAR          revision[4];
    MP_UINT32        supportedLoadBalanceTypes;
} MP_DEVICE_PRODUCT_PROPERTIES;
```

Fields

vendor

Eight bytes of ASCII data identifying the vendor of the device product. Corresponds to the VENDOR IDENTIFICATION field in the SCSI INQUIRY response.

product

Sixteen bytes of ASCII data. Corresponds to the PRODUCT IDENTIFICATION field in the SCSI INQUIRY response. This field can be set with null in all bytes if all devices with the same vendor and revision fields are treated identically by the plugin.

revision

Four bytes of ASCII data. Corresponds to the PRODUCT REVISION LEVEL field in the SCSI INQUIRY response. This field can be set with null in all bytes if all devices with the same vendor and product fields are treated identically by the plugin.

supportedLoadBalanceTypes

A set of flags representing the load balance types (MP_LOAD_BALANCE_TYPES) supported by the device product instance.

Remarks

See the remarks under MP_LOAD_BALANCE_TYPE (see 6.17).

6.27 MP_MULTIPATH_LOGICAL_UNIT_PROPERTIES

Format

```
typedef struct _MP_MULTIPATH_LOGICAL_UNIT_PROPERTIES
{
    MP_CHAR          vendor[8];
    MP_CHAR          product[16];
    MP_CHAR          revision[4];
    MP_CHAR          name[256];
    MP_LOGICAL_UNIT_NAME_TYPE nameType;
    MP_CHAR          deviceFileName[256];
    MP_BOOL          asymmetric;
    MP_OID           overridePath;
    MP_LOAD_BALANCE_TYPE currentLoadBalanceType;
    MP_UINT32        logicalUnitGroupID;
    MP_XBOOL         autoFailbackEnabled;
    MP_UINT32        failbackPollingRateMax;
    MP_UINT32        currentFailbackPollingRate;
    MP_XBOOL         autoProbingEnabled;
    MP_UINT32        probingPollingRateMax;
    MP_UINT32        currentProbingPollingRate;
    MP_UINT32        proprietaryPropertyCount;
    MP_PROPRIETARY_PROPERTY proprietaryProperties[8];
} MP_MULTIPATH_LOGICAL_UNIT_PROPERTIES;
```

Fields

vendor

Eight bytes of ASCII data identifying the vendor of the device product. Corresponds to the VENDOR IDENTIFICATION field in the SCSI INQUIRY response.

product

Sixteen bytes of ASCII data. Corresponds to the PRODUCT IDENTIFICATION field in the SCSI INQUIRY response. This field can be set with null in byte 0 if all devices with the same vendor field are treated identically by the plugin.

revision

Four bytes of ASCII data. Corresponds to the PRODUCT REVISION LEVEL from the SCSI standard inquiry response. This field can be set with null in byte 0 if all devices with the same vendor and product fields are treated identically by the plugin.

name

The name of the device derived from SCSI Inquiry data. If the name is derived from SCSI Device Identification VPD page (i.e., page 83h) and the CODE SET field is 1 (binary), it is translated to hexadecimal-encoded binary.

nameType

The source of the name property.

deviceFileName

The name of the device file representing the consolidated multi-path device. This name shall comply with A.3.

asymmetric

A boolean indicating whether the underlying logical unit has asymmetric access.

overridePath

The ID of a path object only set when an administrator explicitly sets a path.

currentloadBalanceType

The current load balancing preference assigned to this logical unit.

logicalUnitGroupID

The identifier shared by all logical units in a target device that always shared a common access state. If an API request (MP_SetTPGAccess, MP_EnablePath, MP_DisablePath) forces I/Os through a Target Port Group with a different access state, then the target device will force all logical units with a common logicalUnitGroupID to the same access state change.

This property shall correspond to the SCSI logical unit group identifier in a SCSI Device Identification VPD page (i.e., page 83h) response. If the target device does not support this SCSI identifier and the plugin understands a proprietary technique for determining groups of logical units that share access state, then the plugin/driver shall generate a value that acts equivalently to the SCSI defined logical unit group behavior. If the target does not support the SCSI logical unit group identifier and the plugin knows the target has symmetric access through all ports, then the plugin shall set this property to zero. If the target does not support the SCSI page 83h logical unit group identifier and the plugin does not have proprietary knowledge of logical unit groups, then this shall be set to FFFFFFFFh.

autoFailbackEnabled

MP_TRUE if the administrator has requested that auto-failback be enabled for this multipath logical unit. If the plugin's autoFailbackSupport is MP_AUTOFAILBACK_SUPPORT_PLUGINANDMPLU, MP_UNKNOWN is valid and indicates that multipath logical unit has auto-failback enabled if pluginAutoFailbackEnabled is true. Undefined if the plugin's autoFailbackSupport property is MP_AUTOFAILBACK_SUPPORT_NONE or MP_AUTOFAILBACK_SUPPORT_PLUGIN.

failbackPollingRateMax

The maximum polling rate (in seconds) supported by the driver. Zero (0) indicates the driver either does not poll for auto-failback or has not provided an interface to set the polling rate for multipath logical units. If this property and the plugin's failbackPollingRateMax are non-zero, this value has precedence for the associate logical unit. Undefined if the plugin's autoFailbackSupport property is MP_AUTOFAILBACK_SUPPORT_NONE or MP_AUTOFAILBACK_SUPPORT_PLUGIN.

currentFailbackPollingRate

The current polling rate (in seconds) for auto-failback. This cannot exceed failbackPollingRateMax. If this property and the plugin's currentFailbackPollingRate are non-zero, this value has precedence for the associate logical unit. Undefined if the plugin's autoFailbackSupport property is MP_AUTOFAILBACK_SUPPORT_NONE or MP_AUTOFAILBACK_SUPPORT_PLUGIN.

autoProbingEnabled

MP_TRUE if the administrator has requested that auto-probing be enabled for this multipath logical unit. If the plugin's autoProbingSupport is MP_AUTOPROBING_SUPPORT_PLUGINANDMPLU, MP_UNKNOWN is valid and indicates that multipath logical unit has auto-Probing enabled if pluginAutoProbingEnabled is true. Undefined if the plugin's autoProbingSupport property is MP_AUTOPROBING_SUPPORT_NONE or MP_AUTOPROBING_SUPPORT_PLUGIN.

probingPollingRateMax

The maximum polling rate (in seconds) supported by the driver. Zero (0) indicates the driver either does not poll for auto-Probing or has not provided an interface to set the polling rate for multipath logical units. If this property and the plugin's probingPollingRateMax are non-zero, this value has precedence for the associate logical unit. Undefined if the plugin's autoProbingSupport property is MP_AUTOPROBING_SUPPORT_NONE or MP_AUTOPROBING_SUPPORT_PLUGIN.

currentProbingPollingRate

The current polling rate (in seconds) for auto-probing. This cannot exceed probingPollingRateMax. If this property and the plugin's currentProbingPollingRate are non-zero, this value has precedence for the associate logical unit. Undefined if the

plugin's autoProbingSupport property is MP_AUTOPROBING_SUPPORT_NONE or MP_AUTOPROBING_SUPPORT_PLUGIN.
proprietaryPropertyCount
The count of proprietary properties (less than or equal to eight) supported.
proprietaryProperties
A list of proprietary property name/value pairs.

Remarks

MP_MULTIPATH_LOGICAL_UNIT_PROPERTIES represents an aggregation of paths presented as a virtual device to applications (or drivers higher in the stack). Each MP_PATH_LOGICAL_UNIT_PROPERTIES has a set of associated paths (MP_PATH_LOGICAL_UNIT_PROPERTIES).

6.28 MP_STATISTICS_UNSUPPORTED

Constants

```
#define MP_STATISTICS_UNSUPPORTED 0xFFFFFFFFFFFFFFFF
```

Definitions

Constant to indicate that a statistics counter or timer field is not supported.

See Also

MP_PATH_LOGICAL_UNIT_STATISTICS

6.29 MP_TIME_RESOLUTION_UNIT

Constants

```
#define MP_SEC 1  
#define MP_MILLISEC 2  
#define MP_MICROSEC 3  
#define MP_NANOSEC 4  
#define MP_PICOSEC 5
```

```
typedef MP_UINT32 MP_TIME_RESOLUTION_UNIT
```

Definitions

MP_SEC
The unit of the reported time information is in seconds.
MP_MILLISEC
The unit of the reported time information is in milliseconds.
MP_MICROSEC
The unit of the reported time information is in microseconds.
MP_NANOSEC
The unit of the reported time information is in nanoseconds.
MP_PICOSEC
The unit of the reported time information is in picoseconds.

See Also

MP_GetPathLogicalUnitStatistics and MP_GetPathLogicalUnitDistributedStatistics

6.30 MP_STATISTICS_DATA_TYPE

Constants

```
#define MP_STATISTICS_DATA_TYPE_IO_WAIT_TIME          1<<0
#define MP_STATISTICS_DATA_TYPE_READ_WAIT_TIME       1<<1
#define MP_STATISTICS_DATA_TYPE_WRITE_WAIT_TIME      1<<2
#define MP_STATISTICS_DATA_TYPE_IO_RESPONSE_TIME     1<<3
#define MP_STATISTICS_DATA_TYPE_READ_RESPONSE_TIME   1<<4
#define MP_STATISTICS_DATA_TYPE_WRITE_RESPONSE_TIME  1<<5
#define MP_STATISTICS_DATA_TYPE_BYTES                1<<6
#define MP_STATISTICS_DATA_TYPE_READ_BYTES           1<<7
#define MP_STATISTICS_DATA_TYPE_WRITE_BYTES          1<<8
#define MP_STATISTICS_DATA_TYPE_DATA_BYTES           1<<9
#define MP_STATISTICS_DATA_TYPE_DATA_READ_BYTES      1<<10
#define MP_STATISTICS_DATA_TYPE_DATA_WRITE_BYTES     1<<11
#define MP_STATISTICS_DATA_TYPE_CONTROL_BYTES        1<<12
#define MP_STATISTICS_DATA_TYPE_CONTROL_READ_BYTES   1<<13
#define MP_STATISTICS_DATA_TYPE_CONTROL_WRITE_BYTES  1<<14
#define MP_STATISTICS_DATA_TYPE_PROPRIETARY1         1<<23
#define MP_STATISTICS_DATA_TYPE_PROPRIETARY2         1<<24
// additional proprietary types
```

```
typedef MP_UINT32 MP_STATISTICS_DATA_TYPE
```

Definitions

MP_STATISTICS_DATA_TYPE_IO_WAIT_TIME
The distributed statistics data bucket contains I/O wait time data.

MP_STATISTICS_DATA_TYPE_READ_WAIT_TIME
The distributed statistics data bucket contains read operation wait time data.

MP_STATISTICS_DATA_TYPE_WRITE_WAIT_TIME
The distributed statistics data bucket contains write operation wait time data.

MP_STATISTICS_DATA_TYPE_IO_RESPONSE_TIME
The distributed statistics data bucket contains I/O response time data.

MP_STATISTICS_DATA_TYPE_READ_RESPONSE_TIME
The distributed statistics data bucket contains read operation response time data.

MP_STATISTICS_DATA_TYPE_WRITE_RESPONSE_TIME
The distributed statistics data bucket contains write operation response time data.

MP_STATISTICS_DATA_TYPE_BYTES
The distributed statistics data bucket contains number of bytes read or written for both data and control related operations.

MP_STATISTICS_DATA_TYPE_READ_BYTES
The distributed statistics data bucket contains number of bytes read for both data and control related operations.

MP_STATISTICS_DATA_TYPE_WRITE_BYTES
The distributed statistics data bucket contains number of bytes written for both data and control related operations.

MP_STATISTICS_DATA_TYPE_DATA_BYTES
The distributed statistics data bucket contains number of data bytes read or written.

MP_STATISTICS_DATA_TYPE_DATA_READ_BYTES
The distributed statistics data bucket contains number of data bytes read.

MP_STATISTICS_DATA_TYPE_DATA_WRITE_BYTES
The distributed statistics data bucket contains number of data bytes written.

MP_STATISTICS_DATA_TYPE_CONTROL_BYTES

The distributed statistics data bucket contains number of control data bytes read or written.

MP_STATISTICS_DATA_TYPE_CONTROL_READ_BYTES

The distributed statistics data bucket contains number of control data bytes read.

MP_STATISTICS_DATA_TYPE_CONTROL_WRITE_BYTES

The distributed statistics data bucket contains number of control data bytes written.

MP_STATISTICS_DATA_TYPE_TYPE_PROPRIETARYx

The data type of distributed statistics that the bucket contains is proprietary. This bit mask supports up to sixteen proprietary types.

See Also

MP_GetPathLogicalUnitDistributedStatistics

Remarks

The statistics data type is used within the context of MP_PATH_LOGICAL_UNIT_DISTRIBUTED_STATISTICS.

6.31 MP_STATISTICS_BUCKET

Format

```
typedef struct _MP_STATISTICS_BUCKET
{
    MP_UINT64 boundary;
    MP_UINT32 count;
} MP_STATISTICS_BUCKET
```

Fields

boundary:

Sets the inclusive upper limit of a range relative to the previous bucket. The lower limit for first bucket is 0.

count:

Number of occurrences within the associated range.

See Also

MP_PATH_LOGICAL_UNIT_DISTRIBUTED_STATISTICS

Remarks

The value of the boundary field represents either time or a counter depending on the type of statistics data that the bucket contains.

6.32 MP_DISTRIBUTED_STATISTICS_MODE

Constant

```
#define MP_MODE_DEFAULT 0
typedef MP_UINT32 MP_DISTRIBUTED_STATISTICS_MODE
```

Definition

MP_MODE_DEFAULT:

Indicates that the boundary value of a statistics bucket sets the upper limit of a range as described in MP_STATISTICS_BUCKET.

See Also

MP_PATH_LOGICAL_UNIT_DISTRIBUTED_STATISTICS

Remarks

A value other than MP_MODE_DEFAULT may provide a plugin specific way to interpret the boundary value of MP_STATISTICS_BUCKET. This standard does not define a plugin specific mode.

6.33 MP_PATH_LOGICAL_UNIT_DISTRIBUTED_STATISTICS

Format

```
typedef struct _MP_PATH_LOGICAL_UNIT_DISTRIBUTED_STATISTICS
{
    MP_UINT64 snapTime;
    MP_TIME_RESOLUTION_UNIT timeUnit;
    MP_DISTRIBUTED_STATISTICS_MODE mode;
    MP_UINT32 bucketCount;
    MP_STATISTICS_BUCKET bucket[1];
} MP_PATH_LOGICAL_UNIT_DISTRIBUTED_STATISTICS
```

Fields

snapTime:

The elapsed period between the time the statistics counters were reset and the time statistics counters are taken. It can be used to calculate the delta between two statistics data over a period of time.

timeUnit:

The unit of time value used for the snapTime field and for the boundary field in MP_STATISTICS_BUCKET when the associated bucket represents time based statistics data.

mode:

Indicates how the boundary field of the bucket should to be used to interpret distributed statistics data in the buckets.

bucketCount:

Total number of instances of MP_STATISTICS_BUCKET.

bucket:

Array of buckets. It is expanded per the bucketCount.

See Also

MP_GetPathLogicalUnitDistributedStatistics

6.34 MP_PATH_LOGICAL_UNIT_STATISTICS

Format

```
typedef struct _MP_PATH_LOGICAL_UNIT_STATISTICS
{
    MP_UINT64 snapTime;
    MP_UINT64 ioOps;
    MP_UINT64 readOps;
    MP_UINT64 writeOps;
    MP_UINT64 dataOps;
    MP_UINT64 dataReadOps;
    MP_UINT64 dataWriteOps;
    MP_UINT64 controlOps;
}
```

```

    MP_UINT64 controlReadOps;
    MP_UINT64 controlWriteOps;
    MP_UINT64 bytes;
    MP_UINT64 readBytes;
    MP_UINT64 writeBytes;
    MP_UINT64 dataBytes;
    MP_UINT64 dataReadBytes;
    MP_UINT64 dataWriteBytes;
    MP_UINT64 controlBytes;
    MP_UINT64 controlReadBytes;
    MP_UINT64 controlWriteBytes;
    MP_UINT64 ioResponseTime;
    MP_UINT64 ReadResponseTime;
    MP_UINT64 WriteResponseTime;
    MP_UINT64 ioWaitTime;
    MP_UINT64 readWaitTime;
    MP_UINT64 writeWaitTime;
    MP_TIME_RESOLUTION_UNIT timeUnit;
} MP_PATH_LOGICAL_UNIT_STATISTICS;

```

Fields

snapTime:

The elapsed period between the time the statistics counters were reset and the time statistics counters are taken. It can be used to calculate the delta between two statistics data over a period of time.

ioOps:

Number of I/O operations since the counter reset.

readOps:

Number of read operations since the counter was reset.

writeOps:

Number of write operations since the counter was reset.

dataOps:

Number of data I/O operations.

dataReadOps:

Number of data read operations since the counter was reset.

dataWriteOps:

Number of data write operations since the counter was reset.

controlOps:

Number of control I/O operations since the counter was reset.

controlReadOps:

Number of control read operations since the counter was reset.

controlWriteOps:

Number of control write operations since the counter was reset.

bytes:

Total number of bytes read or written since the counter was reset.

readBytes:

Number of bytes read since the counter was reset.

writeBytes:

Number of bytes written since the counter was reset.

dataBytes:

Total number of data bytes read or written since the counter was reset.

dataReadBytes:

Number of data bytes read since the counter was reset.

dataWriteBytes:

Number of data bytes written since the counter was reset.

controlBytes:
Total number of control bytes read or written since the counter was reset.

controlReadBytes:
Number of control bytes read since the counter was reset.

controlWriteBytes:
Number of control bytes written since the counter was reset.

ioResponseTime:
Cumulative time that I/O operations are actively serviced since the associated counters was reset.

readResponseTime:
Cumulative time that read operations are actively serviced since the associated counters was reset.

writeResponseTime:
Cumulative time that write operations are actively serviced since the associated counters was reset.

ioWaitTime:
Cumulative time that I/O operation requests were waiting to be serviced since the associated counters were reset.

readWaitTime:
Cumulative time that read operation requests were waiting to be serviced since the associated counters were reset.

writeWaitTime:
Cumulative time that write operation requests were waiting to be serviced since the associated counters were reset.

timeUnit:
the time unit used for time related counters including the snapTime field.

Remarks

If the counter reset occurs between two subsequent calls the timers and counters of MP_PATH_LOGICAL_UNIT_STATISTICS structure including the value of the snapTime field may decrease over the calls.

The value of the fields is wrapped around when it reaches to maximally allowed value (FFFFFFFFFFFFFFFF->00h). Therefore, the value of a specific field may decrease over the calls. The value FFFFFFFFFFFFFFFFh is reserved as the indication of an unsupported field within the structure.

The sum of the response time and wait time represents the total duration of I/O operations between the time that they were requested to the associated multipathing support and the time that the multipath logical unit has completed them.

6.35 MP_PATH_LOGICAL_UNIT_PROPERTIES

Format

```
typedef struct _MP_PATH_LOGICAL_UNIT_PROPERTIES
{
    MP_UINT32                weight;
    MP_PATH_STATE            pathState;
    MP_BOOL                  disabled;
    MP_OID                   initiatorPortOid;
    MP_OID                   targetPortOid;
}
```

```

        MP_OID                logicalUnitOid;
        MP_UINT64             logicalUnitNumber;
        MP_CHAR               deviceFileName[256];
        MP_UINT32             busNumber;
        MP_UINT32             portNumber;
    } MP_PATH_LOGICAL_UNIT_PROPERTIES;

```

Fields

weight

The administrator-assigned weight of the path. By default (unless specified by the administrator), all paths are assigned the maximum weight supported by the driver (MP_PLUGIN_PROPERTIES.maximumWeight).

pathState

The path state.

disabled

A boolean indicating that the path is disabled explicitly by the MP_DisablePath API or path weight configuration or implicitly due to path failures.

initiatorPortOid

The object ID of the initiator port associated with the path.

targetPortOid

The object ID of the target port associated with the path.

logicalUnitOid

The object ID of the multipath logical unit associated with the path logical unit.

logicalUnitNumber;

The SCSI logical unit number as a SCSI architecture model (SAM) eight-byte value. Note that in typical cases, the logical unit number.

deviceFileName

The name of the OS device file representing this path, if one exists.

busNumber

On Windows, the bus number associated with the initiator port. Undefined for other platforms.

portNumber

On Windows, the port number associated with the initiator port. Undefined for other platforms.

Remarks

As used throughout this standard, the term “path” applies to a combination of a target port, initiator port and logical unit. Unlike other object/structures defined by this standard, a path does not represent a particular object from the real world, but represents an association between real-world objects. Treating the path as a data-structure allows us to assign it an object ID and treat it like other API objects.

6.36 MP_INITIATOR_PORT_PROPERTIES

Format

```

typedef struct _MP_INITIATOR_PORT_PROPERTIES
{
    MP_CHAR                portID[256];
    MP_PORT_TRANSPORT_TYPE portType;
    MP_CHAR                osDeviceFile[256];
    MP_WCHAR               osFriendlyName[256];
} MP_INITIATOR_PORT_PROPERTIES

```

Fields

portID

The name of the port. This should be a worldwide unique name defined per transport-specific standards; such as a FC port WWN.

portType

The transport type of the port.

osDeviceFile

The OS device file name representing the port on the system. See A.2.

osFriendlyName

An administrator-friendly name for an initiator port. A name that an administrator would likely use to refer to the port, if known.

Remarks

In order to assure interoperability, portID shall be formatted consistently across implementations.

| | |
|-------------------------------|--|
| MP_PORT_TRANSPORT_TYPE_MPNODE | A string representing a platform-specific special device file as described in A.2. |
| MP_PORT_TRANSPORT_TYPE_FC | A PortWWN formatted as 16 unseparated upper case hex digits (e.g. '21000020372D3C73') |
| MP_PORT_TRANSPORT_TYPE_SPI | A host/platform name for the port. This is not an interoperable solution, but SPI ports typically lack names. |
| MP_PORT_TRANSPORT_TYPE_ISCSI | The port name is a string and SHALL be an iSCSI name in "iqn", "eui", or "naa" format as described in the iSCSI RFCs. |
| MP_PORT_TRANSPORT_TYPE_IFB | InfiniBand Global Identifier formatted as 32 unseparated upper case hex digits. |
| MP_PORT_TRANSPORT_TYPE_SAS | A SAS Address formatted as 16 unseparated upper-case hex digit. An additional information such as SAS phy identifier for a narrow port or phy bit mask for a wide port may be concatenated when an SAS Address alone is known to be not world wide unique. (e.g. 5010001526C41700.1 where last digit 1 represents a phy identifier or 5010001526C41700.F0 where last digits F0 represent bit mask for a 8 phy wide port, indicating phy identifier 4~7 are assigned to the associated port.) |
| MP_PORT_TRANSPORT_TYPE_FCOE | An assigned PortWWN formatted same as FC transport type port PortID. |

6.37 MP_TARGET_PORT_PROPERTIES

Format

```
typedef struct _MP_TARGET_PORT_PROPERTIES
{
    MP_CHAR          portID[256];
    MP_UINT32       relativePortID
} MP_TARGET_PORT_PROPERTIES
```

Fields

portID

The name of the port. This should be a worldwide unique name defined in transport-specific standards; such as a FC port WWN.

relativePortID

An integer identifier for the target port. This corresponds to the relative target port identifier field in a SCSI Device Identification Management Network Addresses VPD page (i.e., VPD page 83h, see ISO/IEC 14776-453 (SPC-3)) response, type 4h identifier. Note that this value is constrained to 16 bits in ISO/IEC 14776-453 (SPC-3) and that 0 is reserved. If the target device does not support this interface, this property shall be synthesized by the plugin – set this to 1 for port A, 2 for port B, etc.

Remarks

See the remarks above for MP_INITIATOR_PORT_PROPERTIES (see 6.36).

6.38 MP_TARGET_PORT_GROUP_PROPERTIES

Format

```
typedef struct _MP_TARGET_PORT_GROUP_PROPERTIES
{
    MP_ACCESS_STATE_TYPE    accessState;
    MP_BOOL                 explicitFailover;
    MP_BOOL                 supportsLuAssignment;
    MP_BOOL                 preferredLuPath;
    MP_UINT32               tpgID
} MP_TARGET_PORT_GROUP_PROPERTIES;
```

Fields

accessState

The access state as defined in ISO/IEC 14776-453 (SPC-3).

explicitFailover

Set to true if the target device supports an explicit command to set target port group access state (such as the SCSI SET TARGET PORT GROUPS command)

supportsLuAssignment

A boolean indicating whether the device supports assigning logical units to target port groups. This capability is not based on a standard, but some devices provide this to allow an administrator to optimize throughput by selecting which ports should be used to access specific logical units.

preferredLuPath

A boolean to identify the preferred path to the associated logical units (PREF bit as described in ISO/IEC 14776-453 (SPC-3)) or a vendor-specific interface.

tpgId

An integer identifier for the target port group. This corresponds to the TARGET PORT GROUP field in the REPORT TARGET PORT GROUPS response and the TARGET PORT GROUP field in a SCSI Device Identification VPD page (i.e., page 83h) response, type 5h identifier.

6.39 MP_TPG_STATE_PAIR

Format

```
typedef struct _MP_TPG_STATE_PAIR
{
    MP_OID                 tpgOid;
    MP_ACCESS_STATE_TYPE   desiredState;
} MP_TPG_STATE_PAIR;
```

Fields

tpgOid

The object ID of a target port group instance.

state

The desired state of the target port group.

Remarks

This structure is mandatory if the plugin supports the MP_SetTPGAccess method.

7 APIs

7.1 API overview

APIs to return properties of an object

Many of the APIs return properties of objects. These APIs have names like Puget<object-type>Properties, for example, MP_GetTargetPortProperties.

APIs that associate object instances

Some APIs return object IDs of objects related to another object. For example, MP_GetTargetPortOIDList returns a list of IDs of target port objects that comprise a Target Port Group.

APIs that perform multipath tasks

Includes MP_AssignLogicalUnitToTPG, MP_CancelOverridePath, MP_DisableAutoFailback, MP_DisableAutoProbing, MP_DisablePath, MP_EnableAutoFailback, MP_EnableAutoProbing, MP_EnablePath, MP_SetLogicalUnitLoadBalanceType, MP_SetOverridePath, MP_SetPathWeight, MP_SetPluginLoadBalanceType, MP_SetPollingRate and MP_SetTPGAccess.

Convenience methods

These APIs are not related to multipathing, but provide common programming tasks for clients – MP_CompareOids, MP_FreeOidList, MP_GetAssociatedPluginOid, MP_GetObjectType.

APIs related to installation

MP_DeregisterPlugin and MP_RegisterPlugin

APIs related to events

MP_DeregisterForObjectPropertyChanges, MP_DeregisterForVisibilityChanges,
MP_RegisterForObjectPropertyChanges, MP_RegisterForVisibilityChanges,

Typical discovery scenario

A typical client task starts by discovering a subset of the classes by making a sequence of API calls. Once this subset is discovered, the client may display the results or issue another API call to make a change requested by the user. The general discovery pattern in this API is to use an association API to get a list of associated object IDs, then use a properties API on each object ID to get the details.

The diagram below helps a developer understand which API calls are needed for discovery. The dashed lines include the function name that a client will use to determine which other objects (the arrow end of the line) are associated to a given object (the line-end without an arrow).

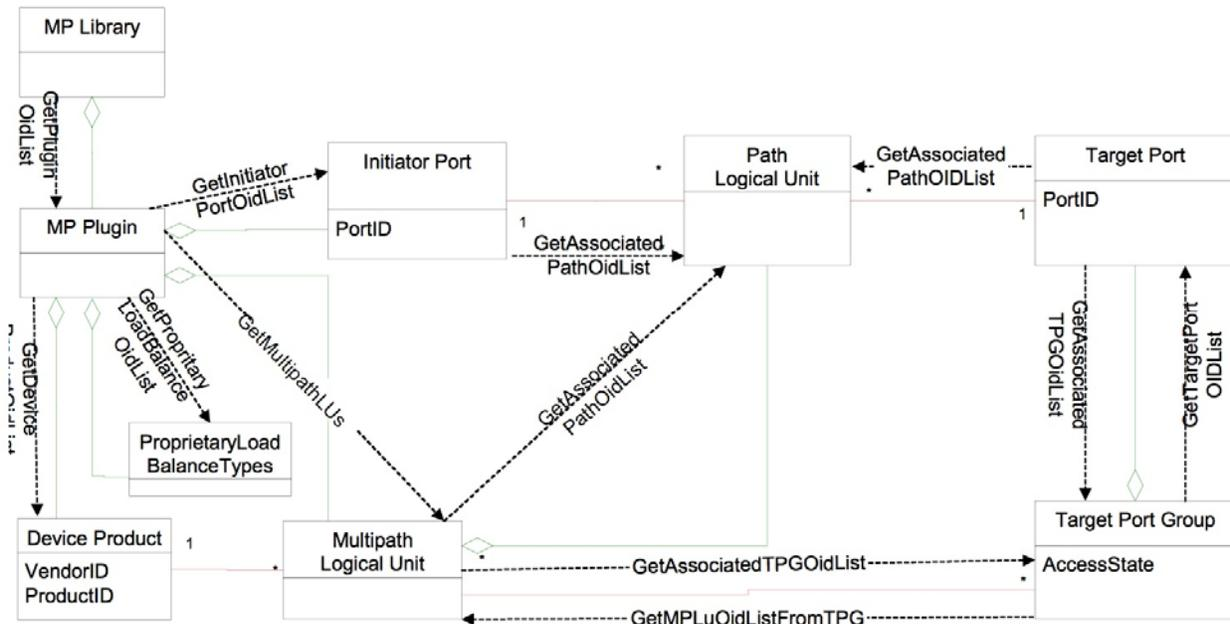

Figure 5 – APIs relative to the objects from Figure 1

Discovery of a model subset typically starts at the library (upper left), finds associated plugins (follow the dashed line) by calling `GetPluginOidList`, then uses `GetPluginProperties` to get plugin details. After that, the client has choices which other classes to navigate, depending on the particular task. If the task requires a list of initiator ports, follow the dashed line to initiator ports (call `GetInitiatorPortOidList`) and get the details using `GetInitiatorPortProperties`. From initiator ports, `GetAssociatedPathOidList` returns a list of paths. The same leapfrog approach can be used to determine which API functions are useful in discovering various subsets of the model.

7.2 MP_AddDeviceProductToPlugin

Synopsis

Add a device product to a plugin supported device product list. The plugin will assign an OID for the device product.

Prototype

```
MP_STATUS MP_AddDeviceProductToPlugin(
    /* in */ MP_OID pluginOid,
    /* in */ MP_DEVICE_PRODUCT_PROPERTIES deviceProduct
);
```

Parameters

pluginOid

A plugin OID.

deviceProduct

A device product to be added.

Typical return values

MP_STATUS_INVALID_OBJECT_TYPE

Returned when *pluginOid* does not specify any valid object type. This is most likely to happen if an uninitialized object ID is passed to the API.

MP_STATUS_INVALID_PARAMETER

Returned when *pluginOid* has a type subfield other than MP_MULTIPATH_LOGICAL_UNIT or the specified load balance type for *deviceProduct* is either invalid or not supported by the plugin.

MP_STATUS_OBJECT_NOT_FOUND

Returned when *pluginOid* owner ID or object sequence number is invalid.

MP_STATUS_SUCCESS

Returned when the operation is successful.

MP_STATUS_REBOOT_NECESSARY

The addition of the device product requires to reboot the host to be effective.

MP_STATUS_UNSUPPORTED

Returned when the API is not supported.

Remarks

Support

Optional.

See Also

MP_RemoveDeviceProductSupportFromPlugin

7.3 MP_AssignLogicalUnitToTPG

Synopsis

Assign a multipath logical unit to a target port group.

Prototype

```
MP_STATUS MP_AssignLogicalUnitToTPG(  
    /* in */ MP_OID tpgOid;  
    /* in */ MP_OID luOid;  
);
```

Parameters

tpgOid

An MP_TARGET_PORT_GROUP *object ID*. The target port group currently in active access state that the administrator would like the LU assigned to.

luOid

An MP_MULTIPATH_LOGICAL_UNIT object ID.

Typical return values

MP_STATUS_INVALID_OBJECT_TYPE

Returned when *tpgOid* or *luOid* does not specify any valid object type. This is most likely to happen if an uninitialized object ID is passed to the API.

MP_STATUS_INVALID_PARAMETER

Returned when *tpgOid* has a type subfield other than MP_OBJECT_TYPE_TARGET_PORT_GROUP or *luOid* has a type subfield other than MP_OBJECT_TYPE_MULTIPATH_LU.

MP_STATUS_OBJECT_NOT_FOUND

Returned when *tpgOid* or *luOid* owner ID or object sequence number is invalid.

MP_STATUS_UNSUPPORTED

Returned when the API is not supported.

MP_STATUS_SUCCESS

Returned when the operation is successful.

Remarks

Only valid if the target port group supportsLuAssignment is true. This capability is not defined in SCSI standards. In some cases, devices support this capability through non-SCSI interfaces. This method is only used when devices support this capability through vendor-specific SCSI commands.

At any given time, each LU will typically be associated with two target port groups, one in active state and one in standby state. The result of this API will be that the LU associations change to a different pair of target port groups. The caller should specify the object ID of the desired target port group in active access state.

Support

Optional.

See also

MP_GetAssociatedTPGOidList

MP_GetMPLuOidListFromTPG

MP_TARGET_PORT_GROUP_PROPERTIES.supportsLuAssignment

7.4 MP_CancelOverridePath

Synopsis

Cancel a path override and re-enable load balancing.

Prototype

```
MP_STATUS MP_CancelOverridePath(  
    /* in */ MP_OID logicalUnitOid;  
);
```

Parameters

logicalUnitOid

An MP_MULTIPATH_LOGICAL_UNIT object ID.

Typical return values

MP_STATUS_INVALID_OBJECT_TYPE

Returned when *logicalUnitOid* does not specify any valid object type. This is most likely to happen if an uninitialized object ID is passed to the API.

MP_STATUS_INVALID_PARAMETER
Returned when *logicalUnitOid* has a type subfield other than
MP_MULTIPATH_LOGICAL_UNIT.
MP_STATUS_OBJECT_NOT_FOUND
Returned when *logicalUnitOid* owner ID or object sequence number is invalid.
MP_STATUS_SUCCESS
Returned when the operation is successful.
MP_STATUS_UNSUPPORTED
Returned when the API is not supported.

Remarks

Only valid if *canOverridePaths* is true in plugin properties.

The previous load balance configuration and preferences in effect before the path was overridden are restored.

Support

Optional.

See also

MP_SetOverridePath

7.5 MP_CompareOIDs

Synopsis

Compare two object IDs for equality to see whether they refer to the same object.

Prototype

```
MP_STATUS MP_CompareOIDs (  
    /* in */ MP_OID oid1;  
    /* in */ MP_OID oid2;  
);
```

Parameters

oid1, oid2

Object IDs for two objects to compare.

Typical return values

MP_STATUS_FAILED

Returned when the object IDs don't compare.

MP_STATUS_SUCCESS

Returned when the two object IDs do refer to the same object.

Remarks

The fields in the two object IDs are compared field-by-field for equality.

Support

Mandatory.

7.6 MP_DeregisterForObjectPropertyChanges

Synopsis

Deregisters a previously registered client function that is to be invoked whenever an object's property changes.

Prototype

```
MP_STATUS MP_DeregisterForObjectPropertyChanges (  
    /* in */   MP_OBJECT_PROPERTY_FN  pClientFn,  
    /* in */   MP_OBJECT_TYPE         objectType,  
    /* in */   MP_OID                 pluginOid  
);
```

Parameters

pClientFn

A pointer to an MP_OBJECT_PROPERTY_FN function defined by the client that was previously registered using the MP_RegisterForObjectPropertyChanges API. On successful return this function will no longer be called to inform the client of object property changes.

objectType

The type of object the client wishes to deregister for property change callbacks. If null, then all object types are deregistered.

pluginOid

If this is a valid plugin object ID, then registration will be removed from that plugin. If this is zero, then registration is removed for all plugins.

Typical return values

MP_STATUS_INVALID_OBJECT_TYPE

Returned when *pluginOid* does not specify any valid object type. This is most likely to happen if an uninitialized object ID is passed to the API.

MP_STATUS_INVALID_PARAMETER

Returned when *pluginOid* is not zero and has a type subfield other than MP_OBJECT_TYPE_PLUGIN.

MP_STATUS_OBJECT_NOT_FOUND

Returned when *pluginOid* owner ID or object sequence number is invalid.

MP_STATUS_UNKNOWN_FN

Returned when *pClientFn* is not the same as the previously registered function.

MP_STATUS_SUCCESS

Returned when *pClientFn* is deregistered successfully.

MP_STATUS_FAILED

Returned when *pClientFn* deregistration is not possible at this time.

Support

Mandatory.

Remarks

The function specified by *pClientFn* takes a single parameter of type MP_OBJECT_PROPERTY_FN.

The function specified by *pClientFn* will no longer be called whenever an object's property changes.

See also

MP_RegisterForObjectPropertyChanges.

7.7 MP_DeregisterForObjectVisibilityChanges

Synopsis

Deregisters a client function to be called whenever a high level object appears or disappears.

Prototype

```
MP_STATUS MP_DeregisterForObjectCreationChanges (  
    /* in */ MP_OBJECT_VISIBILITY_FN pClientFn,  
    /* in */ MP_OBJECT_TYPE          objectType,  
    /* in */ MP_OID                  pluginOid  
);
```

Parameters

pClientFn

A pointer to an MP_OBJECT_VISIBILITY_FN function defined by the client that was previously registered using the MP_RegisterForObjectVisibilityChanges API. On successful return this function will no longer be called to inform the client of object visibility changes.

objectType

The type of object the client wishes to deregister for visibility change callbacks. If null, then all objects types are deregistered.

pluginOid

If this is a valid plugin object ID, then registration will be removed from that plugin. If this is zero, then registration is removed for all plugins.

Typical return values

MP_STATUS_INVALID_OBJECT_TYPE

Returned when *pluginOid* does not specify any valid object type. This is most likely to happen if an uninitialized object ID is passed to the API.

MP_STATUS_INVALID_PARAMETER

Returned when *pluginOid* is not zero or has a type subfield other than MP_OBJECT_TYPE_PLUGIN.

MP_STATUS_OBJECT_NOT_FOUND

Returned when *pluginOid* owner ID or object sequence number is invalid.

MP_STATUS_UNKNOWN_FN

Returned when *pClientFn* is not the same as a previously registered function.

MP_STATUS_SUCCESS

Returned when *pClientFn* is deregistered successfully.

MP_STATUS_FAILED

Returned when *pClientFn* deregistration is not possible at this time

Support

Mandatory.

Remarks

The function specified by *pClientFn* takes a single parameter of type MP_OBJECT_VISIBILITY_FN.

The function specified by *pClientFn* will no longer be called whenever high level objects appear or disappear.

See also

MP_RegisterForObjectVisibilityChanges.

7.8 MP_DeregisterPlugin

Synopsis

Deregisters a plugin from the common library.

Prototype

```
MP_STATUS MP_DeregisterPlugin (  
    /* in */ MP_WCHAR *pPluginId  
);
```

Parameters

pPluginId

A pointer to a Plugin ID previously registered using the MP_RegisterPlugin API.

Typical return values

MP_STATUS_INVALID_PARAMETER

Returned when *pPluginId* is null or specifies a memory area that is not executable.

MP_STATUS_UNKNOWN_FN

Returned when *pPluginId* is not the same as a previously registered function.

MP_STATUS_SUCCESS

Returned when *pPluginId* is deregistered successfully.

MP_STATUS_FAILED

Returned when *pPluginId* deregistration is not possible at this time

Support

Mandatory.

Remarks

The plugin will no longer be invoked by the common library. This API does not dynamically remove the plugin from a running library instance. Instead, it prevents an application that is currently not using a plugin from accessing the plugin. This is generally the behavior expected from dynamically loaded modules.

This API will typically be used during plugin deinstallation or upgrade.

Unlike some other APIs, this API is implemented entirely in the common library.

See also

MP_RegisterPlugin

7.9 MP_DisableAutoFailback

Synopsis

Disables auto-failback for the specified plugin or multipath logical unit.

Prototype

```
MP_STATUS MP_DisableAutoFailback(  
    /* in */ MP_OID oid  
);
```

Parameters

oid

The object ID of the plugin or the multipath logical unit.

Typical Return Values

MP_STATUS_INVALID_OBJECT_TYPE

Returned when *oid* does not specify any valid object type. This is most likely to happen if an uninitialized object ID is passed to the API.

MP_STATUS_INVALID_PARAMETER
 Returned when *oid* has a type subfield other than MP_OBJECT_TYPE_PLUGIN or MP_OBJECT_TYPE_MULTIPATH_LU.

MP_STATUS_OBJECT_NOT_FOUND
 Returned when *oid* owner ID or object sequence number is invalid.

MP_STATUS_SUCCESS
 Returned when the operation is successful

MP_STATUS_UNSUPPORTED
 Returned when the API is not supported.

Support

Mandatory if MP_PLUGIN_PROPERTIES.autoFailbackSupported is not MP_AUTOFAILBACK_SUPPORT_NONE.

See also

MP_EnableAutoFailback

7.10 MP_DisableAutoProbing

Synopsis

Disables auto-probing for the specified plugin or multipath logical unit.

Prototype

```
MP_STATUS MP_DisableAutoProbing(
    /* in */ MP_OID oid
);
```

Parameters

oid
 The object ID of the plugin or the multipath logical unit.

Typical return values

MP_STATUS_INVALID_OBJECT_TYPE
 Returned when *oid* does not specify any valid object type. This is most likely to happen if an uninitialized object ID is passed to the API.

MP_STATUS_INVALID_PARAMETER
 Returned when *oid* has a type subfield other than MP_OBJECT_TYPE_PLUGIN or MP_OBJECT_TYPE_MULTIPATH_LU.

MP_STATUS_OBJECT_NOT_FOUND
 Returned when *oid* owner ID or object sequence number is invalid.

MP_STATUS_SUCCESS
 Returned when the operation is successful.

MP_STATUS_UNSUPPORTED
 Returned when the API is not supported.

Support

Mandatory if MP_PLUGIN_PROPERTIES.autoProbingSupported is not MP_AUTOPROBING_SUPPORT_NONE.

See also

MP_EnableAutoProbing.

7.11 MP_DisablePath

Synopsis

Disables a path. This API may cause failover in a logical unit with asymmetric access.

Prototype

```
MP_STATUS MP_DisablePath(  
    /* in */ MP_OID oid  
);
```

Parameters

oid

The object ID of the path (MP_PATH_LOGICAL_UNIT_PROPERTIES).

Typical return values

MP_STATUS_INVALID_OBJECT_TYPE

Returned when *oid* does not specify any valid object type. This is most likely to happen if an uninitialized object ID is passed to the API.

MP_STATUS_OBJECT_NOT_FOUND

Returned when *oid* owner ID or object sequence number is invalid.

MP_STATUS_INVALID_PARAMETER

Returned when *oid* does not have a type subfield of MP_OBJECT_TYPE_PATH_LU.

MP_STATUS_UNSUPPORTED

Returned when the API is not supported.

MP_STATUS_TRY_AGAIN

Returned when the path cannot be disabled at this time.

MP_STATUS_NOT_PERMITTED

Returned when disabling this path would cause the logical unit to become unavailable. Whether the implementation returns this value or allows the last path to be disabled is implementation specific.

MP_STATUS_SUCCESS

Returned when the operation is successful.

Support

Optional.

Remarks

This API sets MP_PATH_LOGICAL_UNIT_PROPERTIES.disabled to true.

See also

MP_EnablePath.

7.12 MP_EnableAutoFailback

Synopsis

Enables auto-failback.

Prototype

```
MP_STATUS MP_EnableAutoFailback(  
    /* in */ MP_OID oid  
);
```

Parameters

oid

The object ID of the plugin or multipath logical unit.

Typical return values

`MP_STATUS_INVALID_OBJECT_TYPE`

Returned when *oid* does not specify any valid object type. This is most likely to happen if an uninitialized object ID is passed to the API.

`MP_STATUS_INVALID_PARAMETER`

Returned when *oid* has a type subfield other than `MP_OBJECT_TYPE_PLUGIN` or `MP_OBJECT_TYPE_MULTIPATH_LU`.

`MP_STATUS_OBJECT_NOT_FOUND`

Returned when *oid* owner ID or object sequence number is invalid.

`MP_STATUS_SUCCESS`

Returned when the operation is successful.

`MP_STATUS_UNSUPPORTED`

Returned when the API is not supported.

Support

Mandatory if `MP_PLUGIN_PROPERTIES.autoFailbackSupported` is not `MP_AUTOFAILBACK_SUPPORT_NONE`.

See also

`MP_DisableAutoFailback`

7.13 MP_EnableAutoProbing

Synopsis

Enables auto-probing.

Prototype

```
MP_STATUS MP_EnableAutoProbing(  
    /* in */ MP_OID oid  
);
```

Parameters

oid

The object ID of the plugin or multipath logical unit.

Typical return values

`MP_STATUS_INVALID_OBJECT_TYPE`

Returned when *oid* does not specify any valid object type. This is most likely to happen if an uninitialized object ID is passed to the API.

`MP_STATUS_INVALID_PARAMETER`

Returned when *oid* has a type subfield other than `MP_OBJECT_TYPE_PLUGIN` or `MP_OBJECT_TYPE_MULTIPATH_LU`.

`MP_STATUS_OBJECT_NOT_FOUND`

Returned when *oid* owner ID or object sequence number is invalid.

`MP_STATUS_SUCCESS`

Returned when the operation is successful.

`MP_STATUS_UNSUPPORTED`

Returned when the API is not supported.

Support

Mandatory if `MP_PLUGIN_PROPERTIES.autoProbingSupported` is not `MP_AUTOPROBING_SUPPORT_NONE`.

See also

MP_DisableAutoProbing.

7.14 MP_EnablePath**Synopsis**

Enables a path. This API may cause failover in a logical unit with asymmetric access.

Prototype

```
MP_STATUS MP_EnablePath(  
    /* in */ MP_OID oid  
);
```

Parameters

oid

The object ID of the path.

Typical return values

MP_STATUS_INVALID_OBJECT_TYPE

Returned when *oid* does not specify any valid object type. This is most likely to happen if an uninitialized object ID is passed to the API.

MP_STATUS_INVALID_PARAMETER

Returned when *oid* has a type subfield other than MP_OBJECT_TYPE_PATH_LU.

MP_STATUS_OBJECT_NOT_FOUND

Returned when *oid* owner ID or object sequence number is invalid.

MP_STATUS_UNSUPPORTED

Returned when the API is not supported.

MP_STATUS_TRY_AGAIN

Returned when the path cannot be enabled at this time.

MP_STATUS_SUCCESS

Returned when the operation is successful

Support

Optional.

Remarks

This API sets MP_PATH_LOGICAL_UNIT_PROPERTIES.disabled to false.

See also

MP_DisablePath.

7.15 MP_FreeOidList**Synopsis**

Frees memory returned by an MP API.

Prototype

```
MP_STATUS MP_FreeOidList(  
    /* in */ MP_OID_LIST *pOidList  
);
```

Parameters

pOidList

A pointer to an object ID list returned by an MP API. On successful return, the allocated memory is freed.

Typical return values

MP_STATUS_INVALID_PARAMETER

Returned when *pOidList* is null or specifies a memory area to which data cannot be written.

MP_STATUS_SUCCESS

Returned when the operation is successful.

Remarks

Client shall free all **MP_OID_LIST** structures returned by any API by using this function.

Support

Mandatory.

7.16 MP_GetAssociatedPathOidList

Synopsis

Get a list of object IDs for all the path logical units associated with the specified multipath logical unit, initiator port or target port.

Prototype

```
MP_STATUS MP_GetAssociatedPathOidList (  
    /* in */    MP_OID oid,  
    /* out */   MP_OID_LIST **ppList  
);
```

Parameters

oid

The object ID of the multipath logical unit, initiator port or target port.

ppList

A pointer to a pointer to an **MP_OID_LIST** structure. On a successful return, this will contain a pointer to an **MP_OID_LIST** that contains the object IDs of all the paths associated with the specified (multipath) logical unit, initiator port or target port *oid*.

Typical return values

MP_STATUS_INVALID_PARAMETER

Returned when *ppList* is null or specifies a memory area to which data cannot be written or when *oid* has a type subfield other than **MP_OBJECT_TYPE_MULTIPATH_LU**, **MP_OBJECT_TYPE_INITIATOR_PORT** or **MP_OBJECT_TYPE_TARGET_PORT**.

MP_STATUS_INVALID_OBJECT_TYPE

Returned when *oid* does not specify any valid object type. This is most likely to happen if an uninitialized object ID is passed to the API.

MP_STATUS_OBJECT_NOT_FOUND

Returned when *oid* owner ID or object sequence number is invalid.

MP_STATUS_SUCCESS

Returned when the operation is successful.

Remarks

When the caller is finished using the list it shall free the memory used by the list by calling **MP_FreeOidList**.

Support

Mandatory.

See also

MP_GetPathLogicalUnitProperties.

7.17 MP_GetAssociatedPluginOid

Synopsis

Gets the object ID for the plugin associated with the specified object ID.

Prototype

```
MP_STATUS MP_GetAssociatedPluginOid(  
    /* in */    MP_OID oid  
    /* out */   MP_OID *pPluginOid  
);
```

Parameters

oid

The object ID of an object that has been received from a previous API call.

pPluginOid

A pointer to an MP_OID structure allocated by the caller. On successful return this will contain the object ID of the plugin associated with the object specified by *oid*.

Typical return values

MP_STATUS_INVALID_OBJECT_TYPE

Returned when *oid* does not specify any valid object type. This is most likely to happen if an uninitialized object ID is passed to the API.

MP_STATUS_INVALID_PARAMETER

Returned when *pluginOid* is null or specifies a memory area to which data cannot be written.

MP_STATUS_OBJECT_NOT_FOUND

Returned when *oid* owner ID is invalid.

Remarks

The sequence number subfield of *oid* is not validated since this API is implemented in the common library.

Support

Mandatory.

7.18 MP_GetAssociatedTPGOidList

Synopsis

Get a list of the object IDs containing the target port group associated with the specified multipath logical unit.

Prototype

```
MP_STATUS MP_GetAssociatedTPGOidList(  
    /* in */    MP_OID oid,  
    /* out */   MP_OID_LIST **ppList  
);
```

Parameters

oid

The object ID of the multipath logical unit.

ppList

A pointer to a pointer to an MP_OID_LIST structure. On a successful return, this will contain a pointer to an MP_OID_LIST that contains the object IDs of target port groups associated with the specified logical unit.

Typical return values

MP_STATUS_INVALID_OBJECT_TYPE

Returned when *oid* does not specify any valid object type. This is most likely to happen if an uninitialized object ID is passed to the API.

MP_STATUS_INVALID_PARAMETER

Returned when *ppList* is null or specifies a memory area to which data cannot be written or *oid* has a type subfield other than MP_OBJECT_TYPE_MULTIPATH_LU.

MP_STATUS_OBJECT_NOT_FOUND

Returned when *oid* owner ID or object sequence number is invalid.

MP_STATUS_SUCCESS

Returned when the operation is successful.

MP_STATUS_FAILED

Returned when the target port group list for the specified object ID is not found.

MP_STATUS_INSUFFICIENT_MEMORY

Returned when memory allocation failure occurs.

Remarks

When the caller is finished using the list it shall free the memory used by the list by calling MP_FreeOidList.

Support

Mandatory.

See also

MP_GetTargetPortGroupProperties.

7.19 MP_GetDeviceProductOidList

Synopsis

Gets a list of the object IDs of all the device product properties associated with this plugin.

Prototype

```
MP_STATUS MP_GetDeviceProductOidList(  
    /* in */ MP_OID oid,  
    /* out */ MP_OID_LIST **ppList  
);
```

Parameters

oid

The object ID of the plugin.

ppList

A pointer to a pointer to an MP_OID_LIST structure. On a successful return, this will contain a pointer to an MP_OID_LIST that contains the object IDs of all the device product descriptors associated with the specified plugin.

Typical return values

MP_STATUS_INVALID_OBJECT_TYPE

Returned when *oid* does not specify any valid object type. This is most likely to happen if an uninitialized object ID is passed to the API.

MP_STATUS_INVALID_PARAMETER

Returned when *ppList* is null or specifies a memory area to which data cannot be written *oid* has a type subfield other than MP_OBJECT_TYPE_PLUGIN.

MP_STATUS_OBJECT_NOT_FOUND

Returned when *oid* owner ID or object sequence number is invalid.

MP_STATUS_SUCCESS

Returned when the operation is successful.

MP_STATUS_FAILED

Returned when the plugin for the specified object ID is not found.

MP_STATUS_INSUFFICIENT_MEMORY

Returned when memory allocation failure occurs.

MP_STATUS_UNSUPPORTED

Returned when the API is not supported.

Remarks

When the caller is finished using the list it shall free the memory used by the list by calling MP_FreeOidList.

Support

Required if the driver supports product-specific load balance types.

See also

MP_GetDeviceProductProperties.

7.20 MP_GetDeviceProductProperties

Synopsis

Get the properties of the specified device product.

Prototype

```
MP_STATUS MP_GetDeviceProductProperties(  
    /* in */    MP_OID oid,  
    /* out */   MP_DEVICE_PRODUCT_PROPERTIES *pProps  
);
```

Parameters

oid

The object ID of the device product.

pProps

A pointer to an MP_DEVICE_PRODUCT_PROPERTIES structure allocated by the caller. On successful return this structure will contain the properties of the device product specified by *oid*.

Typical return values

MP_STATUS_INVALID_OBJECT_TYPE

Returned when *oid* does not specify any valid object type. This is most likely to happen if an uninitialized object ID is passed to the API.

MP_STATUS_OBJECT_NOT_FOUND

Returned when *oid* owner ID or object sequence number is invalid.

MP_STATUS_INVALID_PARAMETER
 Returned when *pProps* is null or specifies a memory area to which data cannot be written or *oid* has a type subfield other than MP_OBJECT_TYPE_DEVICE_PRODUCT.

MP_STATUS_SUCCESS
 Returned when the operation is successful.

MP_STATUS_FAILED
 Returned when the plugin for the specified *oid* is not found.

MP_STATUS_UNSUPPORTED
 Returned when the implementation does not support the API.

Support

Required if the driver supports product-specific load balance types.

See also

MP_GetDeviceProductOidList.

7.21 MP_GetInitiatorPortOidList

Synopsis

Gets a list of the object IDs of all the initiator ports associated with this plugin.

Prototype

```
MP_STATUS MP_GetInitiatorPortOidList(
    /* in */ MP_OID oid,
    /* out */ MP_OID_LIST **ppList
);
```

Parameters

oid

The object ID of the plugin.

ppList

A pointer to a pointer to an MP_OID_LIST structure. On a successful return, this will contain a pointer to an MP_OID_LIST that contains the object IDs of all the initiator ports associated with the specified plugin.

Typical return values

MP_STATUS_INVALID_OBJECT_TYPE
 Returned when *oid* does not specify any valid object type. This is most likely to happen if an uninitialized object ID is passed to the API.

MP_STATUS_INVALID_PARAMETER
 Returned when *ppList* is null or specifies a memory area to which data cannot be written or when *oid* has a type subfield other than MP_OBJECT_TYPE_PLUGIN.

MP_STATUS_OBJECT_NOT_FOUND
 Returned when *oid* owner ID or object sequence number is invalid.

MP_STATUS_SUCCESS
 Returned when the operation is successful.

MP_STATUS_INSUFFICIENT_MEMORY
 Returned when memory allocation failure occurs.

Remarks

When the caller is finished using the list it shall free the memory used by the list by calling MP_FreeOidList.

Support

Mandatory.

See also

MP_GetInitiatorPortProperties.

7.22 MP_GetInitiatorPortProperties

Synopsis

Gets the properties of the specified initiator port.

Prototype

```
MP_STATUS MP_GetInitiatorPortProperties(  
    /* in */ MP_OID oid,  
    /* out */ MP_INITIATOR_PORT_PROPERTIES *pProps  
);
```

Parameters

oid

The object ID of the port.

pProps

A pointer to an MP_INITIATOR_PORT_PROPERTIES structure allocated by the caller. On successful return, this structure will contain the properties of the port specified by *oid*.

Typical return values

MP_STATUS_INVALID_PARAMETER

Returned when *pProps* is null or specifies a memory area to which data cannot be written or when *oid* has a type subfield other than MP_OBJECT_TYPE_INITIATOR_PORT.

MP_STATUS_INVALID_OBJECT_TYPE

Returned when *oid* does not specify any valid object type. This is most likely to happen if an uninitialized object ID is passed to the API.

MP_STATUS_OBJECT_NOT_FOUND

Returned when *oid* owner ID or object sequence number is invalid.

MP_STATUS_SUCCESS

Returned when the operation is successful.

Support

Mandatory.

See also

MP_GetInitiatorPortOidList.

7.23 MP_GetLibraryProperties

Synopsis

Gets the properties of the MP library that is being used.

Prototype

```
MP_STATUS MP_GetLibraryProperties(  
    /* out */ MP_LIBRARY_PROPERTIES *pProps  
);
```

Parameters

pProps

A pointer to an `MP_LIBRARY_PROPERTIES` structure allocated by the caller. On successful return this structure will contain the properties of the MP library that is being used.

Typical return values

`MP_STATUS_INVALID_PARAMETER`

Returned when *pProps* is null or specifies a memory area which cannot be written.

`MP_STATUS_SUCCESS`

Returned when the operation is successful.

Support

Mandatory.

See also

Example of Getting Library Properties.

7.24 MP_GetMPLuOidListFromTPG

Synopsis

Returns the list of object IDs for multipath logical units associated with the specific target port group.

Prototype

```
MP_STATUS MP_GetMPLuOidListFromTPG(  
    /* in */   MP_OID   oid,  
    /* out */  MP_OID   **ppList  
);
```

Parameters

oid

The object ID of the target port group.

ppList

A pointer to a pointer to an `MP_OID_LIST` structure. On successful return, this will contain a pointer to an `MP_OID_LIST` that contains the object IDs of all the (multipath) logical units associated with the specified target port group.

Typical return values

`MP_STATUS_INVALID_OBJECT_TYPE`

Returned when *oid* does not specify any valid object type. This is most likely to happen if an uninitialized object ID is passed to the API.

`MP_STATUS_INVALID_PARAMETER`

Returned when *pplist* is null or specifies a memory area to which data cannot be written or when *oid* has a type subfield other than `MP_OBJECT_TYPE_TARGET_PORT`.

`MP_STATUS_OBJECT_NOT_FOUND`

Returned when *oid* owner ID or object sequence number is invalid.

`MP_STATUS_SUCCESS`

Returned when the operation is successful.

`MP_STATUS_FAILED`

Returned when the multipath logical unit list for the specified target port group object ID is not found

MP_STATUS_INSUFFICIENT_MEMORY
Returned when memory allocation failure occurs.

Remarks

When the caller is finished using the list it shall free the memory used by the list by calling MP_FreeOidList.

Support

Mandatory.

See also

MP_GetMPLogicalUnitProperties.

7.25 MP_GetMPLogicalUnitProperties

Synopsis

Get the properties of the specified logical unit.

Prototype

```
MP_STATUS MP_GetMPLogicalUnitProperties(  
    /* in */   MP_OID      oid,  
    /* out */  MP_MULTIPATH_LOGICAL_UNIT_PROPERTIES *pProps  
);
```

Parameters

oid

The object ID of the multipath logical unit.

pProps

A pointer to an MP_MULTIPATH_LOGICAL_UNIT_PROPERTIES structure allocated by the caller. On successful return, this structure will contain the properties of the multipath logical unit specified by *oid*.

Typical Return Values

MP_STATUS_INVALID_PARAMETER

Returned when *pProps* is null or specifies a memory area to which data cannot be written or when *oid* has a type subfield other than MP_OBJECT_TYPE_MULTIPATH_LU.

MP_STATUS_INVALID_OBJECT_TYPE

Returned when *oid* does not specify any valid object type. This is most likely to happen if an uninitialized object ID is passed to the API.

MP_STATUS_OBJECT_NOT_FOUND

Returned when *oid* owner ID or object sequence number is invalid.

MP_STATUS_LU_NONOPERATIONAL

Returned when the plugin and the multipathing driver cannot acquire the properties of the multipath logical unit associated with *oid* because it is not operational.

MP_STATUS_SUCCESS

Returned when the operation is successful

Support

Mandatory.

See also

MP_GetMPLuOidListFromTPG.

MP_GetMultipathLus.

7.26 MP_GetMultipathLus

Synopsis

Returns a list of multipath logical units associated to a plugin.

Prototype

```
MP_STATUS MP_GetMultipathLus(  
    /* in */   MP_OID      oid,  
    /* out */  MP_OID_LIST **ppList  
);
```

Parameters

oid

The object ID of the plugin or device product object.

ppList

A pointer to a pointer to an MP_OID_LIST structure. On a successful return, this will contain a pointer to an MP_OID_LIST that contains the object IDs of all the (multipath) logical units associated with the specified plugin object ID.

Typical return values

MP_STATUS_INVALID_OBJECT_TYPE

Returned when *oid* does not specify any valid object type. This is most likely to happen if an uninitialized object ID is passed to the API.

MP_STATUS_INVALID_PARAMETER

Returned when *ppList* is null or specifies a memory area that cannot be written or when *oid* has a type subfield other than MP_OBJECT_TYPE_DEVICE_PRODUCT or MP_OBJECT_TYPE_PLUGIN.

MP_STATUS_OBJECT_NOT_FOUND

Returned when *oid* owner ID or object sequence number is invalid.

MP_STATUS_SUCCESS

Returned when the operation is successful.

MP_STATUS_FAILED

Returned when the plugin for the specified object ID is not found.

MP_STATUS_INSUFFICIENT_MEMORY

Returned when memory allocation failure occurs.

Remarks

When the caller is finished using the list it shall free the memory used by the list by calling MP_FreeOidList.

Support

Mandatory.

See also

MP_GetLogicalUnitProperties.

7.27 MP_GetObjectType

Synopsis

Gets the object type of an initialized object ID.

Prototype

```
MP_STATUS MP_GetObjectType(  
    /* in */   MP_OID oid,  
    /* out */  MP_OBJECT_TYPE *pObjectType
```

Multipath Management API

SNIA Technical Position
Version 1.1

```
);
```

Parameters

oid

The initialized object ID to get the type of.

pObjectType

A pointer to an MP_OBJECT_TYPE variable allocated by the caller. On successful return it will contain the object type of *oid*.

Typical return values

MP_STATUS_INVALID_OBJECT_TYPE

Returned when *oid* does not specify any valid object type. This is most likely to happen if an uninitialized object ID is passed to the API.

MP_STATUS_INVALID_PARAMETER

Returned when *pObjectType* is null or specifies a memory area to which data cannot be written.

MP_STATUS_SUCCESS

Returned when the operation is successful.

Remarks

This API is provided so that clients can determine the type of object an object ID represents. This can be very useful for a client function that receives notifications.

Support

Mandatory.

See also

MP_RegisterForObjectVisibilityChanges.

7.28 MP_GetPathLogicalUnitStatistics

Synopsis

Get the statistics counter of the specified path logical unit.

Prototype

```
MP_STATUS MP_GetPathLogicalUnitStatistics(  
    /* in */    MP_OID oid,  
    /* out */   MP_PATH_LOGICAL_UNIT_STATISTICS *pStatistics  
);
```

Parameters

oid

The OID of a path logical unit.

pStatistics

A pointer to an MP_PATH_LOGICAL_UNIT_STATISTICS structure allocated by the caller. On successful return, this structure will contain the statistics counter of the path specified by *oid*.

Typical return values

MP_STATUS_INVALID_PARAMETER

Returned when *pStats* is null or specifies a memory area to which data cannot be written or when *oid* has a type subfield other than MP_OBJECT_TYPE_PATH_LU.

MP_STATUS_INVALID_OBJECT_TYPE

Returned when *oid* does not specify any valid object type. This is most likely to happen if an uninitialized object ID is passed to the API.

MP_STATUS_OBJECT_NOT_FOUND

Returned when *oid* owner ID or object sequence number is invalid.

MP_STATUS_SUCCESS

Returned when the operation is successful.

Remarks

Either data category or both data and control categories may be provided for number of I/O operations and byte counts by the associated multipath support. For read and write categories, number of I/O operations, byte counts, response time and wait time may be subdivided into those categories if the associated multipathing support provides such division. If they are, both read and write categories shall be provided. The MP_STATISTICS_UNSUPPORTED is set for any field that is not supported by the associated multipathing support.

Support

Mandatory

See also

MP_GetAssociatedPathOidList, MP_GetPathLogicalUnitDistributedStatistics. Example of Getting Statistics on a Path Logical Unit.

7.29 MP_GetPathLogicalUnitDistributedStatistics

Synopsis

Get the distributed statistics of the specified path.

Prototype

```
MP_STATUS MP_GetPathLogicalUnitDistributedStatistics(  
    /* in */ MP_OID oid,  
    /* in */ MP_STATISTICS_DATA_TYPE dataType,  
    /* out */ MP_PATH_LOGICAL_UNIT_DISTRIBUTED_STATISTICS  
    *pStatistics  
);
```

Parameters

oid

The object ID of the path logical unit.

dataType

The requested data type of distributed statistics data.

pStatistics

A pointer to the MP_PATH_LOGICAL_UNIT_DISTRIBUTED_STATISTICS structure.

Typical return values

MP_STATUS_INVALID_PARAMETER

Returned when *pStats* is null or specifies a memory area to which data cannot be written or when *oid* has a type subfield other than MP_OBJECT_TYPE_PATH_LU.

MP_STATUS_INVALID_OBJECT_TYPE

Returned when *oid* does not specify any valid object type. This is most likely to happen if an uninitialized object ID is passed to the API.

MP_STATUS_OBJECT_NOT_FOUND

Returned when *oid* owner ID or object sequence number is invalid.

MP_STATUS_MORE_DATA

Returned when a plugin supports distributed statistics for the given data type and the bucketCount within pStatistics structure is less than the actual number of buckets. The bucket counter indicates the actual number of buckets and the client can determine the size of buffer to be passed.

MP_STATUS_UNSUPPORTED

Returned when a plugin does not support the interface.

MP_STATUS_SUCCESS

Returned when the operation is successful.

Remarks

The bucketCount field from the MP_DISTRIBUTED_STATISTICS structure represents the size of the bucket array within the input buffer pointed by pStatistics. It is caller's responsibility to allocate appropriate size of buffer based on the value of the bucketCount field.

The client needs to call this interface with a specific type of MP_STATISTICS_DATA_TYPE to find out if a particular statistics data type is supported. If the interface itself is not supported the associated multipathing support shall return MP_STATUS_UNSUPPORTED for all statistics data types.

Support

Optional

See also

MP_GetAssociatedPathOidList, MP_GetPathLogicalUnitStatistics. Getting the Distributed Statistics on a Path Logical Unit.

7.30 MP_GetPathLogicalUnitProperties

Synopsis

Get the properties of the specified path.

Prototype

```
MP_STATUS MP_GetPathLogicalUnitProperties(  
    /* in */ MP_OID oid,  
    /* out */ MP_PATH_LOGICAL_UNIT_PROPERTIES *pProps  
);
```

Parameters

oid

The object ID of the path logical unit.

pProps

A pointer to an MP_PATH_LOGICAL_UNIT_PROPERTIES structure allocated by the caller. On successful return, this structure will contain the properties of the path specified by *oid*.

Typical return values

MP_STATUS_INVALID_PARAMETER

Returned when *pProps* is null or specifies a memory area to which data cannot be written or when *oid* has a type subfield other than MP_OBJECT_TYPE_PATH_LU.

MP_STATUS_INVALID_OBJECT_TYPE

Returned when *oid* does not specify any valid object type. This is most likely to happen if an uninitialized object ID is passed to the API.

MP_STATUS_OBJECT_NOT_FOUND

Returned when *oid* owner ID or object sequence number is invalid.

MP_STATUS_SUCCESS

Returned when the operation is successful.

Support

Mandatory.

See also

MP_GetAssociatedPathOidList.

7.31 MP_GetPluginOidList

Synopsis

Gets a list of the object IDs of all currently loaded plugins.

Prototype

```
MP_STATUS MP_GetPluginOidList(  
    /* out */ MP_OID_LIST **ppList  
);
```

Parameters

ppList

A pointer to a pointer to an MP_OID_LIST. On successful return this will contain a pointer to an MP_OID_LIST that contains the object IDs of all of the plugins currently loaded by the library.

Typical return values

MP_STATUS_INVALID_PARAMETER

Returned when *ppList* is null or specifies a memory area to which data cannot be written.

MP_STATUS_SUCCESS

Returned when the operation is successful.

MP_STATUS_FAILED

Returned when the plugin for the specified object ID is not found.

MP_STATUS_INSUFFICIENT_MEMORY

Returned when memory allocation failure occurs.

Remarks

The returned list is guaranteed to not contain any duplicate entries.

When the caller is finished using the list it shall free the memory used by the list by calling MP_FreeOidList.

Support

Mandatory.

See also

MP_FreeOidList, MP_GetPluginProperties, Example of Getting Plugin Properties.

7.32 MP_GetPluginProperties

Synopsis

Gets the properties of the specified plugin.

Prototype

```
MP_STATUS MP_GetPluginProperties(  
    /* in */   MP_OID oid,  
    /* out */  MP_PLUGIN_PROPERTIES *pProps  
);
```

Parameters

oid

The object ID of the plugin.

pProps

A pointer to an MP_PLUGIN_PROPERTIES structure allocated by the caller. On successful return, this structure will contain the properties of the plugin specified by *oid*.

Typical return values

MP_STATUS_INVALID_PARAMETER

Returned when *pProps* is null or specifies a memory area to which data cannot be written or when *oid* has a type subfield other than MP_OBJECT_TYPE_PLUGIN.

MP_STATUS_INVALID_OBJECT_TYPE

Returned when *oid* does not specify any valid object type. This is most likely to happen if an uninitialized object ID is passed to the API.

MP_STATUS_OBJECT_NOT_FOUND

Returned when *oid* owner ID or object sequence number is invalid.

MP_STATUS_SUCCESS

Returned when the operation is successful.

Support

Mandatory.

See also

MP_GetProprietaryLoadBalanceProperties.

MP_GetPluginOidList.

7.33 MP_GetProprietaryLoadBalanceOidList

Synopsis

Gets a list of the object IDs of all the proprietary load balance algorithms associated with this plugin.

Prototype

```
MP_STATUS MP_GetProprietaryLoadBalanceOidList(  
    /* in */   MP_OID oid,  
    /* out */  MP_OID_LIST **ppList  
);
```

Parameters

oid

Multipath Management API

SNIA Technical Position
Version 1.1

The object ID of the plugin.

ppList

A pointer to a pointer to an MP_OID_LIST structure. On a successful return, this will contain a pointer to an MP_OID_LIST that contains the object IDs of all the proprietary load balance types associated with the specified plugin.

Typical return values

MP_STATUS_INVALID_OBJECT_TYPE

Returned when *oid* does not specify any valid object type. This is most likely to happen if an uninitialized object ID is passed to the API.

MP_STATUS_INVALID_PARAMETER

Returned when *ppList* is null or specifies a memory area to which data cannot be written or if *oid* has a type subfield other than MP_OBJECT_TYPE_PLUGIN.

MP_STATUS_OBJECT_NOT_FOUND

Returned when *oid* owner ID or object sequence number is invalid.

MP_STATUS_SUCCESS

Returned when the operation is successful.

MP_STATUS_FAILED

Returned when the plugin for the specified object ID is not found.

MP_STATUS_INSUFFICIENT_MEMORY

Returned when memory allocation failure occurs.

MP_STATUS_UNSUPPORTED

Returned when the implementation does not support the API.

Remarks

When the caller is finished using the list it shall free the memory used by the list by calling MP_FreeOidList.

Support

Optional.

See also

MP_GetProprietaryLoadBalanceProperties.

7.34 MP_GetProprietaryLoadBalanceProperties

Synopsis

Get the properties of the specified load balance properties structure.

Prototype

```
MP_STATUS MP_GetProprietaryLoadBalanceProperties (  
    /* in */    MP_OID oid,  
    /* out */   MP_PROPRIETARY_LOAD_BALANCE_PROPERTIES *pProps  
);
```

Parameters

oid

The object ID of the proprietary load balance structure.

pProps

A pointer to an MP_PROPRIETARY_LOAD_BALANCE_PROPERTIES structure allocated by the caller. On successful return, this structure will contain the properties of the proprietary load balance algorithm specified by *oid*.

Typical return values

MP_STATUS_INVALID_PARAMETER

Returned when *pObjectType* is null or specifies a memory area to which data cannot be written or when *oid* has a type subfield other than MP_OBJECT_TYPE_PROPRIETARY_LOAD_BALANCE.

MP_STATUS_INVALID_OBJECT_TYPE

Returned when *oid* does not specify any valid object type. This is most likely to happen if an uninitialized object ID is passed to the API.

MP_STATUS_OBJECT_NOT_FOUND

Returned when *oid* owner ID or object sequence number is invalid.

MP_STATUS_SUCCESS

Returned when the operation is successful.

Support

Optional.

See also

MP_GetProprietaryLoadBalanceOidList.

7.35 MP_GetTargetPortGroupProperties

Synopsis

Get the properties of the specified target port group.

Prototype

```
MP_STATUS MP_GetTargetPortGroupProperties(  
    /* in */    MP_OID oid,  
    /* out */   MP_TARGET_PORT_GROUP_PROPERTIES *pProps  
);
```

Parameters

oid

The object ID of the target port group.

pProps

A pointer to an MP_TARGET_PORT_GROUP_PROPERTIES structure allocated by the caller. On successful return, this structure will contain the properties of the target port group specified by *oid*.

Typical return values

MP_STATUS_INVALID_PARAMETER

Returned when *pProps* is null or specifies a memory area to which data cannot be written or when *oid* has a type subfield other than MP_OBJECT_TYPE_TARGET_PORT_GROUP.

MP_STATUS_INVALID_OBJECT_TYPE

Returned when *oid* does not specify any valid object type. This is most likely to happen if an uninitialized object ID is passed to the API.

MP_STATUS_OBJECT_NOT_FOUND

Returned when *oid* owner ID or object sequence number is invalid.

MP_STATUS_SUCCESS

Returned when the operation is successful.

Remarks

None.

Support

Mandatory.

See also

MP_GetAssociatedTPGOidList.

7.36 MP_GetSupportedDeviceProductCategory

Synopsis

Get the supported device product categories for a plugin.

Prototype

```
MP_STATUS MP_GetSupportedDeviceProductCategory(  
    /* in */   MP_OID pluginOid,  
    /* out */  MP_SUPPORTED_DEVICE_PRODUCT_CATEGORY  
    *pDeviceProductCat  
);
```

Parameters

pluginOid

The object ID of the plugin.

pDeviceProductCat

A pointer to an MP_SUPPORTED_DEVICE_PRODUCT_CATEGORY flag. On successful return, this flag will indicate which categories are supported by the plugin.

Typical return values

MP_STATUS_INVALID_PARAMETER

Returned when *pDeviceProductCat* is null or specifies a memory area to which data cannot be written or when *pluginOid* has a type subfield other than MP_OBJECT_TYPE_PLUGIN.

MP_STATUS_INVALID_OBJECT_TYPE

Returned when *pluginOid* does not specify any valid object type. This is most likely to happen if an uninitialized object ID is passed to the API.

MP_STATUS_OBJECT_NOT_FOUND

Returned when *pluginOid* owner ID or object sequence number is invalid.

MP_STATUS_SUCCESS

Returned when the operation is successful.

Remarks

If the onlySupportsSpecifiedProducts in the MP_PLUGIN_PROPERTIES structure is set to true, this interface provides more granular device product support information.

Support

Optional.

See also

MP_SUPPORTED_DEVICE_PRODUCT_CATEGORY

7.37 MP_GetTargetPortOidList

Synopsis

Get a list of the object IDs of the target ports in the specified target port group.

Prototype

```
MP_STATUS MP_GetTargetPortOidList(  
    /* in */   MP_OID oid,  
    /* out */  MP_OID_LIST **ppList  
);
```

Parameters

oid

The object ID of the target port group.

ppList

A pointer to a pointer to an MP_OID_LIST structure. On a successful return, this will contain a pointer to an MP_OID_LIST that contains the object IDs of all the target ports associated with the specified target port group *oid*.

Typical return values

MP_STATUS_INVALID_OBJECT_TYPE

Returned when *oid* does not specify any valid object type. This is most likely to happen if an uninitialized object ID is passed to the API.

MP_STATUS_INVALID_PARAMETER

Returned when *ppList* is null or specifies a memory area to which data cannot be written or when *oid* has a type subfield other than MP_OBJECT_TYPE_TARGET_PORT.

MP_STATUS_OBJECT_NOT_FOUND

Returned when *oid* owner ID or object sequence number is invalid.

MP_STATUS_SUCCESS

Returned when the operation is successful.

MP_STATUS_FAILED

Returned when the target port group for the specified object ID is not found.

MP_STATUS_INSUFFICIENT_MEMORY

Returned when memory allocation failure occurs.

Remarks

When the caller is finished using the list it shall free the memory used by the list by calling MP_FreeOidList.

Support

Mandatory.

See also

MP_GetTargetPortProperties.

7.38 MP_GetTargetPortProperties

Synopsis

Gets the properties of the specified target port.

Prototype

```
MP_STATUS MP_GetTargetPortProperties(  
    /* in */   MP_OID oid,  
    /* out */  MP_TARGET_PORT_PROPERTIES *pProps  
);
```

Parameters

oid

The object ID of the port.

pProps

A pointer to an MP_TARGET_PORT_PROPERTIES structure allocated by the caller. On successful return, this structure will contain the properties of the port specified by *oid*.

Typical return values

MP_STATUS_INVALID_PARAMETER

Returned when *pProps* is null or specifies a memory area to which data cannot be written or when *oid* has a type subfield other than MP_OBJECT_TYPE_TARGET_PORT.

MP_STATUS_INVALID_OBJECT_TYPE

Returned when *oid* does not specify any valid object type. This is most likely to happen if an uninitialized object ID is passed to the API.

MP_STATUS_OBJECT_NOT_FOUND

Returned when *oid* owner ID or object sequence number is invalid.

MP_STATUS_SUCCESS

Returned when the operation is successful.

Support

Mandatory.

See also

MP_GetTargetPortOidList.

7.39 MP_RegisterForObjectPropertyChanges

Synopsis

Registers a client function to be called whenever the property of an object changes.

Prototype

```
MP_STATUS MP_RegisterForObjectPropertyChanges (  
    /* in */ MP_OBJECT_PROPERTY_FN pClientFn,  
    /* in */ MP_OBJECT_TYPE        objectType,  
    /* in */ void                  *pCallerData,  
    /* in */ MP_OID                pluginOid  
);
```

Parameters

pClientFn

A pointer to an MP_OBJECT_PROPERTY_FN function defined by the client. On successful return this function will be called to inform the client of objects that have had one or more properties change.

objectType

The type of object the client wishes to register for property change callbacks. If MP_OBJECT_TYPE_UNKNOWN, then all object types are registered.

pCallerData

A pointer that is passed to the callback routine with each event. This may be used by the caller to correlate the event to source of the registration.

pluginOid

If this is a valid plugin object ID, then registration will be limited to that plugin. If this is zero, then the registration is for all plugins.

Typical return values

MP_STATUS_INVALID_OBJECT_TYPE

Returned when *pluginOid* or *objectType* does not specify any valid object type. This is most likely to happen if an uninitialized object ID is passed to the API.

MP_STATUS_OBJECT_NOT_FOUND

Returned when *pluginOid* owner ID or object sequence number is invalid.

MP_STATUS_INVALID_PARAMETER

Returned when *pCallerData* is null or if *pluginOid* has a type subfield other than MP_OBJECT_TYPE_PLUGIN or when *objectType* is invalid.

MP_STATUS_SUCCESS

Returned when the operation is successful.

MP_STATUS_FN_REPLACED

Returned when an existing client function is replaced with the one specified in *pClientFn*.

Support

Mandatory.

Remarks

The function specified by *pClientFn* takes a single parameter of type MP_OBJECT_PROPERTY_FN.

The function specified by *pClientFn* will be called whenever the property of an object changes. For the purposes of this function a property is defined to be a field in an object's property structure and the object's status. Therefore, the client function will not be called if a statistic of the associated object changes. But, it will be called when the status changes (e.g. from working to failed) or when a name or other field in a property structure changes.

It is not an error to re-register a client function. However, a client function has only one registration. The first call to deregister a client function will deregister it no matter how many calls to register the function have been made.

If multiple properties of an object change simultaneously, a client function may be called only once to be notified that the changes have occurred.

See also

MP_DeregisterForObjectPropertyChanges.

7.40 MP_RegisterForObjectVisibilityChanges

Synopsis

Registers a client function to be called whenever a high level object appears or disappears.

Prototype

```
MP_STATUS MP_RegisterForObjectVisibilityChanges (  
    /* in */ MP_OBJECT_VISIBILITY_FN    pClientFn,  
    /* in */ MP_OBJECT_TYPE            objectType,  
    /* in */ void                       *pCallerData,  
    /* in */ MP_OID                    pluginOid  
);
```

Parameters

pClientFn

A pointer to an MP_OBJECT_VISIBILITY_FN function defined by the client. On successful return this function will be called to inform the client of objects whose visibility has changed.

objectType

The type of object the client wishes to register for visibility change callbacks. If MP_OBJECT_TYPE_UNKNOWN, then all objects types are registered.

pCallerData

A pointer that is passed to the callback routine with each event. This may be used by the caller to correlate the event to source of the registration.

pluginOid

If this is a valid plugin object ID, then registration will be limited to that plugin. If this is zero, then the registration is for all plugins.

Typical return values

MP_STATUS_INVALID_OBJECT_TYPE

Returned when *pluginOid* or *objectType* does not specify any valid object type. This is most likely to happen if an uninitialized object ID is passed to the API.

MP_STATUS_OBJECT_NOT_FOUND

Returned when *pluginOid* owner ID or object sequence number is invalid.

MP_STATUS_INVALID_PARAMETER

Returned when *pCallerData* is null or *pluginOid* has a type subfield other than MP_OBJECT_TYPE_PLUGIN or when *objectType* is invalid.

MP_STATUS_SUCCESS

Returned when the operation is successful.

MP_STATUS_FN_REPLACED

Returned when an existing client function is replaced with the one specified in *pClientFn*.

Support

Mandatory.

Remarks

The function specified by *pClientFn* takes a single parameter of type MP_OBJECT_VISIBILITY_FN.

The function specified by *pClientFn* will be called whenever objects appear or disappear.

It is not an error to re-register a client function. However, a client function has only one registration. The first call to deregister a client function will deregister it, no matter how many calls to register the function have been made.

See also

MP_DeregisterForObjectVisibilityChanges.

7.41 MP_RegisterPlugin

Synopsis

Registers a plugin with the common library. In a POSIX environment, this may be implemented by adding an entry to a conf file. In Windows, it may be accomplished with a registry entry.

Prototype

```
MP_STATUS MP_RegisterPlugin (
    /* in */   MP_WCHAR      *pPluginId,
    /* in */   MP_CHAR       *pFileName
);
```

Parameters

pPluginId

A pointer to the key name shall be the reversed domain name of the vendor followed by "." followed by the vendor specific name for the plugin that uniquely identifies the plugin.

pFileName

The full path to the plugin library.

Typical return values

MP_STATUS_INVALID_PARAMETER

Returned when *pFileName* does not exist.

MP_STATUS_SUCCESS

Returned when the operation is successful.

Support

Mandatory.

Remarks

Unlike some other APIs, this API is implemented entirely in the common library. It shall be called before the common library will invoke a plugin.

This API does not impact, dynamically add or change plugins bound to a running library instance. Instead, it causes an application that is currently not using a plugin to access the specified plugin on future calls to the common library. This is generally the behavior expected from dynamically loaded modules.

This API is typically called by a plugin's installation software to inform the common library the path for the plugin library.

It is not an error to re-register a plugin. However, a plugin has only one registration. The first call to deregister a plugin will deregister it, no matter how many calls to register the plugin have been made.

A vendor may register multiple plugins by using separate plugin IDs and filenames.

See also

MP_DeregisterPlugin.

7.42 MP_RemoveDeviceProductFromPlugin

Synopsis

Remove a device product from a plugin support.

Prototype

```
MP_STATUS MP_RemoveDeviceProductFromPlugin(  
    /* in */ MP_OID pluginOid,  
    /* in */ MP_OID deviceProductOid  
);
```

Parameters

pluginOid

A pluginOid.

deviceProductOid

A device product to be removed.

Typical return values

MP_STATUS_INVALID_OBJECT_TYPE

Returned when *pluginOid* or *deviceProductOid* does not specify any valid object type. This is most likely to happen if an uninitialized object ID is passed to the API.

MP_STATUS_INVALID_PARAMETER

Returned when *pluginOid* or *deviceProductOid* has a type subfield other than MP_MULTIPATH_LOGICAL_UNIT or MP_DEVICE_PRODUCT_TYPE.

MP_STATUS_OBJECT_NOT_FOUND

Return when *pluginOid* or *deviceProductOid* owner ID or object sequence number is invalid.

MP_STATUS_SUCCESS

Returned when the operation is successful.

MP_STATUS_REBOOT_NECESSARY

The addition of the device product requires to reboot the host to be effective.

MP_STATUS_UNSUPPORTED

Returned when the API is not supported.

Remarks

Support

Optional.

See Also

MP_AddDeviceProductSupportToPlugin

7.43 MP_SendSCSICommand

Synopsis

Send a SCSI command to a multipath logical unit through a specific path logical unit.

Prototype

```
MP_STATUS MP_SendSCSICommand(  
    /* in */ MP_OID logicalUnitOid,  
    /* in */ MP_OID pathOid,  
    /* in */ MP_CHAR *cmdBuffer,  
    /* in */ MP_UINT32 cmdBufferSize,  
    /* out */ MP_CHAR *dataInBuffer,  
    /* in */ MP_UINT32 dataInBufferSize,  
    /* out */ MP_BYTE scsiStatus,  
    /* out */ MP_CHAR *senseBuffer,  
    /* in */ MP_UINT32 *senseBufferSize,  
    /* in */ MP_UINT32 cmdTimeOutValue,  
    /* in & out */ MP_CHAR *dataOutBuffer,  
    /* in */ MP_UINT32 dataOutBufferSize,  
    /* out */ MP_UINT32 residualCount,  
    /* in */ MP_UINT32 proprietaryMode  
)
```

Parameters

logicalUnitOid

The object ID of the multipath logical unit to receive the command.

PathOid

The object ID of the path logical unit to send the command down.

CmdBuffer

A buffer to pass SCSI CDB

cmdBufferSize

The size of SCSI CDB buffer

dataInBuffer

A buffer to store any data to be received by the logical unit device.

dataInBufferSize

The size of the data-in buffer

scsiStatus

SCSI status for the command

senseBuffer

A buffer to store SCSI sense data

senseBufferSize

The size of sense buffer

cmdTimeoutValue

The time out value to be applied for the command.

dataOutBuffer

A buffer to receive the data from a device.

dataOutBufferSize

The size of data-out buffer

residualCount

The residual count for an incomplete SCSI data transfer.

proprietaryMode

Proprietary mode flag to be passed to the plugin that owns the logical unit.

Typical return values

MP_STATUS_INVALID_OBJECT_TYPE

Returned when *logicalUnitOid* or *pathOid* does not specify any valid object type. This is most likely to happen if an uninitialized object ID is passed to the API.

MP_STATUS_INVALID_PARAMETER

Returned when *logicalUnitOid* or *pathOid* has a type subfield other than MP_OBJECT_TYPE_MULTIPATH_LU or MP_OBJECT_TYPE_PATH_LU.

MP_STATUS_OBJECT_NOT_FOUND

Returned when owner ID or object sequence number of *logicalUnitOid* or *pathOid* is invalid.

MP_STATUS_FAILED

Returned when the plugin and the associated multipathing driver failed to pass down the command.

MP_STATUS_NOT_PERMITTED

Returned when the command was not permitted by the plugin or the multipathing driver.

MP_STATUS_UNSUPPORTED

Returned when the implementation does not support the API.

MP_STATUS_SUCCESS

Returned when the command was passed down successfully. The `scsiStatus` field contains the actual status of the SCSI command

Support

Mandatory

7.44 MP_SetDeviceProductLoadBalanceType

Synopsis

Set the device product's load balancing policy.

Prototype

```
MP_STATUS MP_SetDeviceProductBalanceType(  
    /* in */ MP_OID deviceProductOid,  
    /* in */ MP_LOAD_BALANCE_TYPE loadBalance  
);
```

Parameters

deviceProductOid

The object ID of the device product.

loadBalance

The desired load balance policy for the specified logical unit.

Typical return values

MP_STATUS_INVALID_OBJECT_TYPE

Returned when *deviceProductOid* does not specify any valid object type. This is most likely to happen if an uninitialized object ID is passed to the API.

MP_STATUS_INVALID_PARAMETER

Returned when *loadBalance* is invalid or *deviceProductOid* has a type subfield other than MP_OBJECT_TYPE_MULTIPATH_LU.

MP_STATUS_OBJECT_NOT_FOUND

Returned when *deviceProductOid* owner ID or object sequence number is invalid

MP_STATUS_SUCCESS

Returned when the operation is successful.

MP_STATUS_FAILED

Returned when the specified *loadBalance* type cannot be handled by the associated plugin.

MP_STATUS_UNSUPPORTED

Returned when the implementation does not support the API.

Remarks

The value shall correspond to one of the supported values in `MP_PLUGIN_PROPERTIES.SupportedLogicalUnitLoadBalanceTypes`.

Support

Optional.

7.45 MP_SetLogicalUnitLoadBalanceType

Synopsis

Set the multipath logical unit's load balancing policy.

Prototype

```
MP_STATUS MP_SetLogicalUnitLoadBalanceType(  
    /* in */ MP_OID logicalUnitOid,  
    /* in */ MP_LOAD_BALANCE_TYPE loadBalance  
);
```

Parameters

logicalUnitOid

The object ID of the multipath logical unit.

loadBalance

The desired load balance policy for the specified logical unit.

Typical return values

MP_STATUS_INVALID_OBJECT_TYPE

Returned when *logicalUnitOid* does not specify any valid object type. This is most likely to happen if an uninitialized object ID is passed to the API.

MP_STATUS_INVALID_PARAMETER

Returned when *loadBalance* is invalid or *logicalUnitOid* has a type subfield other than MP_OBJECT_TYPE_MULTIPATH_LU.

MP_STATUS_OBJECT_NOT_FOUND

Returned when *logicalUnitOid* owner ID or object sequence number is invalid

MP_STATUS_SUCCESS

Returned when the operation is successful.

MP_STATUS_FAILED

Returned when the specified *loadBalance* type cannot be handled by the plugin. One possible reason is a request to set MP_LOAD_BALANCE_TYPE_PRODUCT when the specified logical unit has no corresponding MP_DEVICE_PRODUCT_PROPERTIES instance (i.e. the plugin does not have a product-specific load balance algorithm for the LU product).

MP_STATUS_UNSUPPORTED

Returned when the implementation does not support the API.

Remarks

The value shall correspond to one of the supported values in MP_PLUGIN_PROPERTIES.SupportedLogicalUnitLoadBalanceTypes.

Support

Optional.

7.46 MP_SetOverridePath

Synopsis

Manually override the path for a logical unit. The path exclusively used to access the logical unit until cleared. Use MP_CancelOverride to clear the override.

Prototype

```
MP_STATUS MP_SetOverridePath(  
    /* in */ MP_OID logicalUnitOid,  
    /* in */ MP_OID pathOid  
);
```

Parameters

logicalUnitOid

The object ID of the multipath logical unit.

pathOid

The object ID of the path logical unit.

Typical return values

MP_STATUS_INVALID_OBJECT_TYPE

Returned when *logicalUnitOid* or *pathOid* does not specify any valid object type. This is most likely to happen if an uninitialized object ID is passed to the API.

MP_STATUS_INVALID_PARAMETER

Returned when *logicalUnitOid* has a type subfield other than MP_OBJECT_TYPE_MULTIPATH_LU or if *pathOid* has an object type other than MP_OBJECT_TYPE_PATH_LU.

MP_STATUS_OBJECT_NOT_FOUND

Returned when *logicalUnitOid* or *pathOid* owner ID or object sequence number is invalid.

MP_STATUS_SUCCESS

Returned when the operation is successful.

MP_STATUS_UNSUPPORTED

Returned when the implementation does not support the API.

MP_STATUS_PATH_NONOPERATIONAL

Returned when the driver cannot communicate through a selected path.

Remarks

This API allows the administrator to disable the driver's load balance algorithm and force all I/O to a specific path. The existing path weight configuration is maintained. If the administrator undoes the override (by calling MP_CancelOverridePath), the driver will start load balancing based on the weights of available paths (and target port group access state for asymmetric devices).

If the multipath logical unit is part of a target with asymmetrical access, executing this command could cause failover.

Support

Optional.

7.47 MP_SetPathWeight

Synopsis

Set the weight to be assigned to a particular path.

Prototype

```
MP_STATUS MP_SetPathWeight(  
    /* in */ MP_OID pathOid,  
    /* in */ MP_UINT32 weight  
);
```

Parameters

logicalUnitOid

The object ID of the path logical unit.

weight

A weight that will be assigned to the path logical unit.

Typical return values

MP_STATUS_INVALID_OBJECT_TYPE

Returned when *pathOid* does not specify any valid object type. This is most likely to happen if an uninitialized object ID is passed to the API.

MP_STATUS_OBJECT_NOT_FOUND

Returned when *pathOid* ownerID or object sequence number is invalid.

MP_STATUS_INVALID_PARAMETER

Returned when *pathOid* has a type subfield other than MP_OBJECT_TYPE_PATH_LU or when the weight parameter is greater than the plugin's maximumWeight property.

MP_STATUS_SUCCESS

Returned when the operation is successful.

MP_STATUS_FAILED

Returned when the operation failed.

MP_STATUS_UNSUPPORTED

Returned when the driver does not support setting path weight.

Support

Optional.

7.48 MP_SetPluginLoadBalanceType

Synopsis

Set the default load balance policy for the plugin.

Prototype

```
MP_STATUS MP_SetPluginLoadBalanceType(  
    /* in */ MP_OID oid,  
    /* in */ MP_LOAD_BALANCE_TYPE loadBalance  
);
```

Parameters

oid

The object ID of the plugin.

loadBalance

The desired default load balance policy for the specified plugin.

Typical return values

MP_STATUS_INVALID_OBJECT_TYPE

Returned when *oid* does not specify any valid object type. This is most likely to happen if an uninitialized object ID is passed to the API.

MP_STATUS_INVALID_PARAMETER

Returned when *loadBalance* is invalid or when *oid* has a type subfield other than MP_OBJECT_TYPE_PLUGIN.

MP_STATUS_OBJECT_NOT_FOUND

Returned when *oid* ownerID or sequence number is invalid.

MP_STATUS_SUCCESS

Returned when the operation is successful.

MP_STATUS_FAILED

Returned when the specified loadBalance type cannot be handled by the plugin.

MP_STATUS_UNSUPPORTED

Returned when the implementation does not support the API.

Remarks

The value shall correspond to one of the supported values in MP_PLUGIN_PROPERTIES.SupportedPluginLoadBalanceTypes.

Support

Optional.

7.49 MP_SetFailbackPollingRate

Synopsis

Set the polling rates. Setting pollingRate to zero disables polling.

Prototype

```
MP_STATUS MP_SetPollingRate(  
    /* in */ MP_OID      oid,  
    /* in */ MP_UINT32   pollingRate  
);
```

Parameters

oid

An object ID of either the plugin or a multipath logical unit.

pollingRate

The value to be set in MP_PLUGIN_PROPERTIES currentFailbackPollingRate or MP_MULTIPATH_LOGICAL_UNIT_PROPERTIES failbackPollingRate.

Typical return values

MP_STATUS_INVALID_OBJECT_TYPE

Returned when *oid* does not specify any valid object type. This is most likely to happen if an uninitialized object ID is passed to the API.

MP_STATUS_INVALID_PARAMETER

Returned when one of the polling values is outside the range supported by the driver or when *oid* has a type subfield other than MP_OBJECT_TYPE_PLUGIN or MP_OBJECT_TYPE_MULTIPATH_LU.

MP_STATUS_OBJECT_NOT_FOUND

Returned when *oid* ownerID or object sequence number is invalid.

MP_STATUS_SUCCESS

Returned when the operation is successful.

MP_STATUS_UNSUPPORTED

Returned when the implementation does not support the API.

Remarks

If the object ID refers to a plugin, then this will set the currentFailbackPollingRate property in the plugin properties. If the object ID refers to a multipath logical unit, this sets the failbackPollingRate property.

Support

Optional.

See also

MP_AUTOFAILBACK_SUPPORT.

7.50 MP_SetProbingPollingRate

Synopsis

Set the polling rates. Setting pollingRate to zero disables polling.

Prototype

```
MP_STATUS MP_SetPollingRate(  
    /* in */ MP_OID      oid,  
    /* in */ MP_UINT32   pollingRate  
);
```

Parameters

oid

An object ID of either the plugin or a multipath logical unit.

pollingRate

The value to be set in MP_PLUGIN_PROPERTIES currentProbingPollingRate or MP_MULTIPATH_LOGICAL_UNIT_PROPERTIES ProbingPollingRate.

Typical return values

MP_STATUS_INVALID_OBJECT_TYPE

Returned when *oid* does not specify any valid object type. This is most likely to happen if an uninitialized object ID is passed to the API.

MP_STATUS_INVALID_PARAMETER

Returned when one of the polling values is outside the range supported by the driver or when *oid* has a type subfield other than MP_OBJECT_TYPE_PLUGIN or MP_OBJECT_TYPE_MULTIPATH_LU.

MP_STATUS_OBJECT_NOT_FOUND

Returned when *oid* ownerID or sequence number is invalid.

MP_STATUS_SUCCESS

Returned when the operation is successful.

MP_STATUS_UNSUPPORTED

Returned when the implementation does not support the API.

Remarks

If the object ID refers to a plugin, then this will set the currentProbingPollingRate property in the plugin properties. If the object ID refers to a multipath logical unit, this sets the ProbingPollingRate property.

Support

Optional.

See also

MP_AUTOPROBING_SUPPORT.

7.51 MP_SetProprietaryProperties

Synopsis

Set proprietary properties in supported object instances.

Prototype

```
MP_STATUS MP_SetProprietaryProperties (  
    /* in */ MP_OID      oid;  
    /* in */ MP_UINT32   count;  
    /* in */ MP_PROPRIETARY_PROPERTY *pPropertyList;  
);
```

Parameters

oid

The object ID representing an MP_LOAD_BALANCE_PROPIETARY_TYPE, MP_PLUGIN_PROPERTIES, or MP_MULTIPATH_LOGICAL_UNIT_PROPERTIES instance.

count

The number of valid items in pPropertyList.

pPropertyList

A pointer to an array of property name/value pairs. This array shall contain the same number of elements as count.

Typical return values

MP_STATUS_INVALID_OBJECT_TYPE

Returned when *oid* does not specify a valid object type. This is most likely to happen if an uninitialized object ID is passed to the API.

MP_STATUS_OBJECT_NOT_FOUND

Returned when *oid* owner ID or object sequence number is invalid.

MP_STATUS_INVALID_PARAMETER

Returned when *pPropertyList* is null or when one of the properties referenced in the list is not associated with the specified object ID or *oid* has a type subfield other than MP_OBJECT_TYPE_PROPRIETARY_LOAD_BALANCE, MP_OBJECT_TYPE_PLUGIN or MP_OBJECT_TYPE_MULTIPATH_LU.

MP_STATUS_SUCCESS

Returned when the operation is successful.

MP_STATUS_UNSUPPORTED

Returned when the API is not supported.

Remarks

This API allows an application with *a priori* knowledge of proprietary plugin capabilities to set proprietary properties. pPropertyList is a list of property name/value pairs. The property names shall be a subset of the proprietary property names listed in the referenced object ID.

Support

Optional.

7.52 MP_SetTPGAccess

Synopsis

Set the access state for a list of target port groups. This allows a client to force a failover or fallback to a desired set of target port groups.

Prototype

```
MP_STATUS MP_SetTPGAccess (
    /* in */ MP_OID          luOid;
    /* in */ MP_UINT32      count;
    /* in */ MP_TPG_STATE_PAIR *pTpgStateList;
);
```

Parameters

luOid

The object ID of the logical unit where the command is sent.

count

The number of valid items in the pTpgStateList.

pTpgStateList

A pointer to an array of TPG/access-state values. This array shall contain the same number of elements as count.

Typical return values

MP_STATUS_ACCESS_STATE_INVALID

Returned when the target device returns a status indicating the caller is attempting to establish an illegal combination of access states.

MP_STATUS_FAILED

Returned when the underlying interface failed the command for some reason other than MP_STATUS_ACCESS_STATE_INVALID.

MP_STATUS_INVALID_OBJECT_TYPE

Returned when *luOid* does not specify any valid object type. This is most likely to happen if an uninitialized object ID is passed to the API.

MP_STATUS_OBJECT_NOT_FOUND

Returned when *luOid* owner ID or object sequence number is invalid.

MP_STATUS_INVALID_PARAMETER

Returned when *pTpgStateList* is null or when one of the TPGs referenced in the list is not associated with the specified MP logical unit or *luOid* has a type subfield other than MP_OBJECT_TYPE_MULTIPATH_LU.

MP_STATUS_SUCCESS

Returned when the operation is successful.

MP_STATUS_UNSUPPORTED

Returned when the API is not supported.

Remarks

Only valid for devices that support explicit access state manipulation (i.e. MP_TARGET_PORT_GROUP.explicitFailover shall be true).

This API provides the information needed to set up a SCSI SET TARGET PORT GROUPS command. The plugin should not implement this API by directly calling the SCSI SET TARGET PORT GROUPS command. The plugin should use the MP drivers API (e.g. ioctl) if available.

When the caller is finished using the list it shall free the memory used by the list by calling MP_FreeOidList.

Support

Optional.

8 Implementation compliance

An implementation of the API described in this document shall meet the following requirements.

- a) Provide an entry point for each API listed in this document.
- b) Implement all APIs that are listed as mandatory to implement.
- c) Attempt to perform or cause the performance of all of the actions that are specified for an API when all parameters to that API are valid.
- d) Fail an API call if the implementation is aware that one of the requirements specified for that API cannot be satisfied.

9 Implementation notes

9.1 Backwards compatibility

Clients should expect that code written for an earlier version of the API would continue to work with newer implementations of the library and plugins. Revisions to this standard should make all attempts to assure backwards compatibility.

If it is later discovered that this standard is not clear and existing implementations are inconsistent, compatibility cannot be maintained. Alternatively, it may be discovered that an existing interface lacks necessary details. The developers of this standard may need to deprecate an interface in order to assure interoperability going forward. In these cases, the compatibility issues are documented in this standard. A client can look at the version number in the plugin properties to see which version of this standard the plugin implements.

9.2 Client usage notes

9.2.1 Reserved fields

Some structures in the API contain reserved fields. Clients shall ignore the values in any reserved fields in any structures.

9.2.2 Event notification within a single client

The API interfaces for event reporting are described in 5.5. The specific implementation used to deliver events within a client is specific to the library and/or plugin implementation. Therefore, when a client receives an event, it shall not use the thread delivering the event for any significant amount of time. If the work needed to respond to an event is at all significant the client should somehow save the information needed to respond to the event and then have another thread perform the actual work to handle the event. If a client fails to do this, it may delay the delivery of subsequent events and it may even cause events to be lost. The method a client uses to save the data of an event and causes another thread to respond to the event is entirely client specific.

9.2.3 Event notification and multi-threading

A client that uses the event notification APIs of the library shall also be multi-thread safe. A client cannot assume that an event is delivered on the same thread that registered for the event, nor can a client assume that the client created the thread used to deliver the event. The only thing a client can assume about a thread used to deliver an event is, that it was properly initialized to use the C runtime library.

9.3 Library implementation notes

9.3.1 Multi-threading support

Any implementation of this API, i.e. the library, shall be multi-thread safe. That is, the library shall allow a client to safely have multiple threads calling APIs in the library simultaneously. It is the responsibility of the library to synchronize the usage of any library resources being used by different threads.

9.3.2 Event notification and multi-threading

A client shall be able to call any API while the client is handling an event. Therefore, the library implementation shall not leave any resources locked while calling a client's event handler that would be needed if the client's event handler called an API. Otherwise, if the client's event handler did call an API, either the API would have to fail or the calling thread would deadlock waiting for a resource.

9.3.3 Structure packing

In order to ensure compatibility between different implementations of the Multipath Management API, it is necessary that each implementation provides header files and/or document compiler options so that each structure is packed such that there are no padding bytes between structure members.

9.3.4 Calling conventions

In order to maintain compatibility between different versions of implementations of the Multipath Management API, it is necessary that each implementation provides header files and/or document compiler options so that all APIs in the Multipath Management API are called using the C calling convention.

9.4 Plugin implementation notes

9.4.1 Reserved fields

Most structures in the API contain reserved fields. Plugins shall zero out any fields that they consider reserved.

9.4.2 Multi-threading support

Plugins shall also be multi-thread safe. A client shall be able to have multiple threads active at anyone time. It is the responsibility of the plugin to synchronize the usage of plugin resources being used by different threads.

9.4.3 Event notification to different clients

Timely delivery of events to clients is necessary. Therefore, vendor implementations shall not, in any way, serialize delivery of events by plugins. It is not permissible for a vendor implementation to allow one client to significantly delay delivery of events to any other client.

9.4.4 Event notification and multi-threading

A client shall be able to call any API while the client is handling an event. Therefore, a plugin shall not leave any resources locked while calling a client's event handler that would be needed if the client's event handler called an API. Otherwise, if the client's event handler did call an API, either the API would have to fail or the calling thread would deadlock waiting for a resource.

9.4.5 Event overhead conservation

Although not required, it is strongly recommended that the plugin and driver have a coordinated approach to event registration that allows driver/kernel event reporting to be disabled when no clients are registered for types of events. This minimizes kernel overhead in handling events at times when no clients are listening for events.

9.4.6 Function names

Every plugin shall implement functions with the same name as the API functions; that is, the common library API method `MP_GetTargetPortGroupProperties()` will function as a gateway module to parse and invoke the plugin's `MP_GetTargetPortGroupProperties()` method.

Annex A (informative)

Device names

A.1 General

This annex contains information on how to specify the *osDeviceName* field in the MP_MULTIPATH_LOGICAL_UNIT_PROPERTIES. Whenever possible the values used in the fields of these structures are identical to the values used in similar structures in ANSI INCITS 386-2004 (FC-API).

A.2 Initiator port osDeviceName

In the tables below text appearing in bold shall appear in the indicated position exactly as it appears in the sample. Text appearing in italics is a placeholder for other text as determined by the specified operating system Initiator Port osDeviceName.

This table describes recommended values for the *osDeviceName* field of the MP_INITIATOR_PROPERTIES structure.

Table A.1 – Names for the osDeviceName field

| Operating System | Value |
|------------------|--|
| AIX | <i>/dev/fscsin (for an FC initiator), /dev/iscsin (for an iSCSI initiator)</i> |
| HP-UX | <i>/dev/tdn, /dev/fcd<u>n</u></i> |
| Linux | <i>/dev/name</i> |
| Solaris | <i>/devices/name</i> |
| Windows | \\.\Scsin: |

A.3 Logical unit osDeviceName

This table describes recommended values for the *osDeviceName* field of the MP_MULTIPATH_LOGICAL_UNIT_PROPERTIES structure.

Table A.2 – Names for the osDeviceName

| Operating System | Value | | | |
|------------------|--------------|--------|------|---------|
| | Disk/Optical | CD-ROM | Tape | Changer |
| | | | | |

| | | | | |
|---------|---|--|-----------------------------|--------------------------------|
| AIX | <i>/dev/hdisk_n</i> (disk) or <i>/dev/omd_n</i> (optical) | <i>/dev/cd_n</i> | <i>/dev/rmt_n</i> | Empty string |
| HP-UX | <i>/dev/dsk/cxydz</i> | <i>/dev/dsk/cxydz</i> | <i>/dev/rmt/nm</i> | Empty string |
| Linux | <i>/dev/sd_n</i> | <i>/dev/sr_n</i> | <i>/dev/st_n</i> | Empty string |
| Solaris | <i>/dev/rdisk/cxydzs2</i> | <i>/dev/rdisk/cxydzs2</i> | <i>/dev/rmt/nm</i> | Empty string |
| Windows | \\.\PHYSICALDRIV E_n | \\.\CDROM_n .../CDROM_n | \\.\TAPE_n | \\.\CHANGER_n |

Annex B (informative)

Synthesizing target port groups

If the plugin/driver is supporting a device does not implement the ISO/IEC 14776-453 (SPC-3) target port group access interfaces, the plugin/driver should synthesize target port groups. This annex describes how a plugin/driver will implement this behavior. It is assumed that the driver knows device-specific multipath interfaces.

Consider an asymmetric access RAID array with two RAID controllers, each having one port. The steady-state configuration is that some (multipath) logical units are assigned (i.e. optimized) to each controller (which is one-to-one with a port in this example) and that hosts should access those logical units exclusively through the port on the assigned controller.

The device logical units and ports map directly to API path logical units and target ports. In addition, the plugin/driver should synthesize four target port groups. The logical units optimized for one particular port are attached to a target port group in Active/Optimized state.

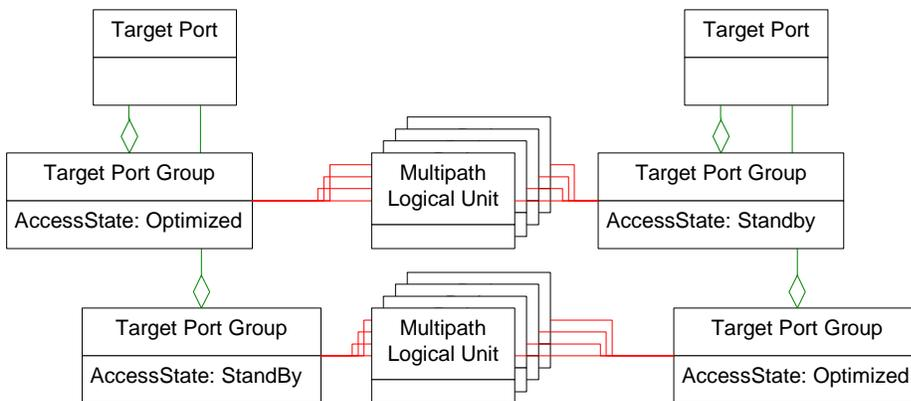

Figure B.1 – Synthetic target port groups

In the case of a hardware-initiated failover or a manual failover (MP_SetTPGAccess) that effectively disables a port, the AccessState changes for both target port groups associated with one port. The table below summarizes the access state changes.

| Old state | New state |
|----------------------|----------------------|
| Active/Optimized | Standby |
| Active/Non-optimized | Standby |
| Standby | Active/Non-optimized |

In the case of a manual failback (MP_SetTPGAccess) to reestablish the steady-state configuration, the states should be changed as depicted in Figure B.1.

Target port groups should be associated with multiple logical units that share the same access state for the associated ports. In other words, the plugin/driver should not synthesize separate target port groups for each logical unit. In other words, MP_GetAssociatiatedTPDOidList should

return the same list of object IDs for all multipath logical units that share the same access states through the same target ports.

If the plugin/driver knows through vendor-specific interfaces that a target device has symmetric logical unit access, it should synthesize a single target port group associated with all logical units and target ports, with access state set to active/optimized.

Annex C

(informative)

Transport layer multipathing

SAS and iSCSI allow multiple physical ports to be aggregated into a virtual SCSI port. This provides a multipath capability at a lower layer than the capabilities in this API. Each approach has advantages.

- Transport-layer multipathing has simpler management capabilities because all LUNs on a target share the same path configuration. Path switching tends to be more efficient at the transport layer than at the higher SCSI layers described in this API.
- SCSI-layer multipathing (as described in this API applies to all SCSI transports and allows failover and load-balancing across transports (for example, an array with FC and iSCSI ports could support failover from FC to iSCSI). SCSI-layer multipathing allows per-LUN configuration.

This standard does not address transport-layer multipathing. Transport-specific management interfaces may be available. There may be cases where both layers of multipathing are available on the same system. As used in this standard, the term “port” applies to the aggregated, virtual port in configurations with transport-layer multipathing.

Annex D (informative)

Coding examples

D.1 General

This annex contains samples of how to use the Multipath Management API. All of these examples are non-normative; if there is a discrepancy between these examples and anything in any of the previous subclauses of this document the examples should be considered incorrect and the previous subclauses correct.

One note about the examples: the examples will all perform error detection; however they will not perform error reporting. This is an exercise left to the reader.

There are three coding examples. They are:

- a) example of getting library properties;
- b) example of getting plugin properties; and
- c) example of discovering path LUs associated with an MP LU.

D.2 Example of getting library properties

```
//  
// This example prints the properties of the MP library.  
//  
MP_STATUS status;  
MP_LIBRARY_PROPERTIES props;  
  
//  
// Try to get the library properties. If this succeeds then print  
// the properties.  
//  
status = MP_GetLibraryProperties(&props);  
if ( Status == MP_STATUS_SUCCESS )  
{  
    printf("Library Properties:\n");  
    printf("\tMP version: %u\n",  
           (unsigned int) props.implementationVersion);  
    printf(L"\tVendor: %s\n", props.vendor);  
    wprintf(L"\tImplementation version: %s\n",  
           props.implementationVersion);  
    printf(L"\tFile name: %s\n", props.fileName);  
    printf("\tBuild date/time: %s\n", DateTime(&props.buildTime));  
}
```

D.3 Example of getting plugin properties

```
//  
// This example gets the properties of the first plugin returned by  
// the library.  
//  
MP_STATUS status;  
MP_OID_LIST *pList;
```

```

//
// Get the list of plugin IDs.
//
status = MP_GetPluginOidList(&pList);
if ( Status == MP_STATUS_SUCCESS )
{
    //
    // Make sure there's a plugin to get the properties of.
    //
    if ( pList->oidCount != 0 )
    {
        MP_PLUGIN_PROPERTIES props;
        status = MP_GetPluginProperties(pList->oids[0], &props);
        if ( Status == MP_STATUS_SUCCESS )
        {
            printf("Plugin Properties:\n");
            printf("\tMP version: %u\n", props.supportedMpVersion);
            wprintf(L"\tVendor: %s\n", props.vendor);
            wprintf(L"\tImplementation version: %s\n",
                    props.implementationVersion);
            printf(L"\tFile name: %s\n", props.fileName);
            printf("\tBuild date/time: %s\n", DateTime(&props.buildTime))
        }
    }
}

//
// Always remember to free an object ID list when it's no longer
// needed. Failing to do so will cause memory leaks.
//
MP_FreeOidList(pList);
}

```

D.4 Example of discovering path LUs associated with an MP LU

```

//
//
// This example prints the name of each multipath logical unit,
// then prints information about each path.
//
MP_STATUS status;
MP_OID_LIST *lulist, *plist;
MP_UNIT32 lu_num, path_num;
MP_MULTIPATH_LOGICAL_UNIT_PROPERTIES luProps;
MP_PATH_LOGICAL_UNIT_PROPERTIES pProps;
MP_TARGET_PORT_PROPERTIES tProps;
MP_INITIATOR_PORT_PROPERTIES iProps;
// Assume we're just operating against one plugin - its
// OID is magically known...
MP_OID pluginOid = xxx;
//
// Get a list of the object IDs of all of the multipath LUs in the
// system.
//
status = MP_GetMultipathLus(pluginOid, &lulist);
if ( status == MP_STATUS_SUCCESS )

```

```

{
//
// For each MP LU, first display some properties, and then get paths
//
mp_num = 0;
while ( lu_num <= lulist->oidCount )
{
    status = MP_GetMPLogicalUnitProperties(lulist->oids[lu_num],
        &luProps);
    // assume status ok for the example...
    printf (L"OS Device %s LU ID %s\n", luProps.deviceFilename,
        luProps.name);
    status = MP_GetAssociatedPathOidList(lulist->oids[lu_num],
        &plist);
    // assume status ok
    path_num = 0;
    while ( path_num < plist->OidCount )
    {
        status = MP_GetPathLogicalUnitProperties(
            plist->oids[path_num], &pProps);
        status = MP_GetInitiatorPortProperties (
            pProps.initiatorPortOid, iProps);
        status = MP_GetInitiatorPortProperties (
            pProps.targetPortOid, tProps);
        printf(L" Initiator: %s Target: %s\n",
            iProps.name, tProps.name);
        MP_FreeOidList(plist);
        path_num++;
    }
    lu_num++;
}
MP_FreeOidList(lulist);
}

```

D.5 Example of getting statistics on a path logical unit

```

// Example for processing statistics data.

MP_PATH_LOGICAL_UNIT_STATISTICS stats1, stats2;
MP_OID patLUOid;
MP_UINT32 sleepTime;
MP_STATUS status;

// Assume the pathLUOid is assigned with an instance of a path
// logical unit.

status = MP_GetPathLogicalUnitStatistics(pathLUOid, &stats1);
if (MP_STATUS_SUCCESS == status) {

    // Assume the associated multipathing support provides data operation
    // related statistics.

    printf("Statistics Data from first call: \n");
    printf("Read Ops\t Write Ops\t Read Bytes\t Write Bytes\n");
}

```

```

    printf("-----\t -----\t -----\t -----\n");
    printf("%8lld\t %8lld\t %8lld\t %8lld\n", stats1.readOps,
        stats1.writeOps, stats1.readBytes, stats1.writeBytes);
} else {
    // handle an error
    return;
}

// Assume sleepTime is assigned a value already.

sleep(sleepTime);
status = MP_GetPathLogicalUnitStatistics(pathLUOid, &stats2);
if (MP_STATUS_SUCCESS == status) {

    // Assume the associated multipathing support provides data operation
    // related statistics.

    printf("Statistics Data from second call: \n");
    printf("Read Ops\t Write Ops\t Read Bytes\t Write Bytes\n");
    printf("-----\t -----\t -----\t -----\n");
    printf("%8lld\t %8lld\t %8lld\t %8lld\n", stats2.readOps,
        stats2.writeOps, stats2.readBytes, stats2.writeBytes);
} else {
    // handle an error
    return;
}

// Assume stats1.timeUnit and stats2.timeUnit are set to MP_MILLISEC.

printf("Sampling data over %lld milliseconds:\n",
    stats2.snapTime - stats1.snapTime);
printf("Read Ops\t Write Ops\t Read Bytes\t Write Bytes\n");
printf("-----\t -----\t -----\t -----\n"),
printf("%8lld\t %8lld\t %8lld\t %8lld\n",
    stats2.readOps - stats1.readOps, stats2.writeOps - stats1.writeOps,
    stats2.readBytes - stats1.readBytes, stats2.writeBytes -
    stats1.writeBytes);

```

D.6 Example of getting distributed statistics on a path logical unit

```

// Example for processing distributed statistics data.

MP_PATH_LOGICAL_UNIT_DISTRIBUTED_STATISTICS *stats;
MP_OID          pathLUOid;
MP_UINT32       sleepTime;
MP_STATUS       status;
int             count = 8;

// Assume the pathLUOid is assigned with an instance of a path logical unit
// and the stats buffer is allocated with the size to hold 8 buckets.

stats = (MP_PATH_LOGICAL_UNIT_DISTRIBUTED_STATISTICS *) calloc(1,
    sizeof(MP_PATH_LOGICAL_UNIT_DISTRIBUTED_STATISTICS) +

```

```

        ((sizeof(MP_STATISTICS_BUCKET)) * (count - 1));

// Store the count to bucketCount field to indicate the size of stats
// buffer.

stats->bucketCount = count;
status = MP_GetPathLogicalUnitDistributedStatistics(pathLUOid,
        MP_STATISTICS_DATA_TYPE_RESPONSE_TIME, stats);
if (MP_STATUS_SUCCESS == status) {

    // Assume the multipathing support also provides 8 buckets of
    // distributed statistics.

    upper_bound = 0;
    printf("I/O Response Data from first call: \n");
    printf("Response time          \tCount of I/Os\n");
    printf("----- \t-----\n");
    for (i = 0; i < stats->bucketCount; i++) {
        lower_bound = upper_bound;
        upper_bound = stats->bucket[i].boundary;
        printf(">%-5lld and <= %-5lld \t%lld\n", lower_bound,
                upper_bound, stats->bucket[i].count);
    }
} else {
    // handle an error
    return;
}

// Assume sleepTime is assigned a value already and stats buffer is
// cleared with 0s.

sleep(sleepTime);
status = MP_GetPathLogicalUnitDistributedStatistics(pathLUOid,
        MP_STATISTICS_DATA_TYPE_RESPONSE_TIME, stats);
if (MP_STATUS_SUCCESS == status) {
    upper_bound = 0;
    printf("I/O Response Data from second call: \n");
    printf("Response time          \tCount of I/Os\n");
    printf("----- \t-----\n");
    for (i = 0; i < stats->bucketCount; i++) {
        lower_bound = upper_bound;
        upper_bound = stats->bucket[i].boundary;
        printf(">%-5lld and <= %-5lld \t%lld\n", lower_bound,
                upper_bound, stats->bucket[i].count);
    }
} else {
    // handle an error
    return;
}

```

Annex E (informative)

Library/plugin API

This annex describes the required interfaces between the library and the plugins for OS-independent implementations.

The common library shall assure that each plugin is given a unique plugin ID. This is the second field (ownerID) in an Object ID as described in 5.7.3.

In most cases, the common library will use the ownerID of an object provided by the caller to determine which plugin owns the object, and then will dynamically invoke that function in the plugin.

The common library should provide the following APIs without invoking plugins:

- MP_CompareOIDs
- MP_FreeOidList
- MP_GetLibraryProperties
- MP_GetPluginOidList
- MP_GetAssociatedPluginOid
- MP_GetObjectType
- MP_RegisterPlugin
- MP_DeregisterPlugin

Each plugin shall provide the following two functions:

- Initialize() - Provided by the plugin to address any initialization tasks.
- Terminate() - Provided by the plugin to address any termination tasks.

These are not used by client applications. They are exclusively used by the common library as part of dynamically loading and unloading plugins.

Annex F
(normative)

Bibliography

Infiniband Architecture Specification Volume 1 Release 1.1, November 2002

NOTE - Copies of Infiniband standards may be obtained through the Infiniband Trade Organization (IBTA) at <http://www.infinibandta.org>.